



**U.S. Department
of Transportation**

Federal Aviation
Administration

Advisory Circular

Subject: MANAGEMENT OF AIRPORT
INDUSTRIAL WASTE

Date: 9/8/2008
Initiated by: AAS-100

AC No: 150/5320-15A
Change:

- 1. PURPOSE.** This advisory circular (AC) provides basic information on the characteristics, management, and regulations of industrial wastes generated at airport and guidance for the development of a Storm Water Pollution Prevention Plan (SWPPP) that applies best management practices to eliminate, prevent, or reduce pollutants in storm water runoff associated with particular airport industrial activities.
- 2. CANCELLATION.** This AC cancels AC 150/5320-15, *Management of Airport Industrial Waste*, dated February 11, 1991, and Change 1, dated April 22, 1997.
- 3. APPLICATION.** The guidelines and recommendations contained in this AC are recommended by the Federal Aviation Administration (FAA) for the management of airport generated wastes at civil airports. This AC offers general guidance for managing airport industrial waste and is not binding or regulatory.
- 4. PRINCIPAL CHANGES.** The following principal changes are incorporated:
 - a.** The vast majority of chapter 8 was replaced by referencing the Airport Cooperative Research Program (ACRP) document ARCP #02-02, *Planning Guidelines and Best Management Practices for Aircraft and Airfield Deicing Stormwater Management Systems*.
 - b.** The concept of waste minimization and recycling deicing fluids.
 - c.** The addition of supplementary Pollution Prevention techniques at airports.
 - d.** The distinction between hazardous waste and non-hazardous waste.

Michael J. O'Donnell
Director, Airport Safety and Standards

Intentionally left blank.

TABLE OF CONTENTS

CHAPTER 1. INTRODUCTION.....	1
1.1. BACKGROUND	1
1.2. AIRPORT INDUSTRIAL WASTES	1
1.3. INDUSTRIAL WASTEWATER REGULATIONS AND WATER QUALITY STANDARDS	1
1.4. HAZARDOUS AND NON-HAZARDOUS WASTE REGULATIONS	2
1.5. DE/ANTI-ICING AND STORM WATER OCCURRING WASTES	2
1.6. DEVELOPING A STORM WATER POLLUTION PREVENTION PLAN.....	2
CHAPTER 2. HAZARDS AND NUISANCES OF AIRPORT INDUSTRIAL WASTE.....	5
2.1. CHARACTERISTICS	5
2.2. INTERFERENCE WITH WATERWAY PURIFICATION OR POTW OPERATION....	5
2.3. CONTAMINATION OF GROUND WATER	6
CHAPTER 3. TYPES OF AIRPORT INDUSTRIAL WASTE.....	7
3.1. CLASSIFICATION	7
3.2. CYANIDES	7
3.3. CHROMIUM COMPOUNDS AND TOXIC METALS	7
3.4. ACIDS AND ALKALIES	8
3.5. ORGANIC SOLVENTS AND PHENOLS	8
3.6. OIL, GREASE, AND/OR DETERGENTS	8
3.7. BATTERIES	8
3.8. DE/ANTI-ICING CHEMICAL WASTES	8
CHAPTER 4. SURVEYS FOR AIRPORT INDUSTRIAL WASTE	9
4.1. OBJECTIVES OF A WASTE SURVEY	9
4.2. REQUIREMENTS OF WASTE SURVEY	9
4.3. FLOW MEASUREMENT.....	9
4.4. SAMPLING.....	9
4.5. ANALYSIS.....	9
4.6. STORMWATER POLLUTION PREVENTION DEVELOPMENT ASSESSMENT	10
CHAPTER 5. MANAGEMENT STRATEGIES FOR AIRPORT INDUSTRIAL WASTE	11
5.1. MANAGEMENT STRATEGIES.....	11
5.2. SOURCE REDUCTION.....	11
5.3. RECOVERY AND REUSE.....	11
5.4. TREATMENT	12
CHAPTER 6. MANAGEMENT OF HAZARDOUS AND NON-HAZARDOUS WASTE	13
6.1. HAZARDOUS WASTES	13
6.2. GENERATOR STATUS	13
6.3. GENERATOR IDENTIFICATION NUMBER	13
6.4. ACCUMULATION TIME	14
6.5. ACCUMULATION UNITS	14
6.6. ONSITE TREATMENT AND DISPOSAL	15
6.7. MANIFESTS	16
6.8. PERSONNEL TRAINING, PREPAREDNESS AND PREVENTION, AND CONTINGENCY PLANS AND EMERGENCY PROCEDURES.....	16
6.9. EMERGENCY PLANNING AND COMMUNITY RIGHT-TO-KNOW	17

CHAPTER 7. AIRPORT INDUSTRIAL WASTES CONVEYANCE AND COLLECTION.....	19
7.1. CONVEYANCE SYSTEMS	19
7.2. SEWER MATERIALS	19
7.3. COLLECTION SYSTEMS	19
CHAPTER 8. MANAGEMENT OF DE/ANTI-ICING CHEMICAL WASTES	21
8.1. GENERAL GUIDANCE	21
8.2. AIRCRAFT DEICING FACILITIES	21
8.3. RUNWAY SURFACE CONDITION MONITORING SYSTEMS.....	21
8.4. LAGOONS AND RETENTION PONDS	21
CHAPTER 9. TREATMENT TECHNIQUES FOR INDUSTRIAL WASTEWATERS.....	23
9.1. GENERAL.....	23
9.2. PHYSICAL UNIT OPERATIONS.....	23
9.3. CHEMICAL UNIT OPERATIONS	24
9.4. MEMBRANE PROCESSES.	25
9.5. BIOLOGICAL UNIT OPERATIONS.....	26
9.6. TERTIARY AND OTHER TREATMENT TECHNOLOGIES	29
9.7. TREATABILITY STUDIES	30
9.8. SLUDGE HANDLING.....	30
CHAPTER 10. MANAGEMENT OF MAINTENANCE SHOP WASTES	31
10.1. GENERAL.....	31
10.2. PLATING ROOM WASTES	31
10.3. SOURCES AND CHARACTERISTICS OF WASTES	31
10.4. PLATING WASTE REDUCTION.....	31
10.5. CHROMIC ACID RECOVERY.....	31
10.6. CHROMIUM REDUCTION	32
10.7. PHENOLIC WASTES.....	33
10.8. CYANIDE WASTES	34
10.9. PAINTING AND PAINT REMOVAL OPERATION.....	35
10.10. OILY WASTES.....	36
CHAPTER 11. MANAGEMENT OF AIRCRAFT WASHES AND SIMILAR WASTES.....	37
11.1. GENERAL.....	37
11.2. WASTE CONTRIBUTORS.....	37
11.3. AIRCRAFT WASH WASTES TREATMENT AND DISPOSAL	37
11.4. SLUDGE DISPOSAL.....	37
CHAPTER 12. AIRPORT-ORIENTED STORM WATER POLLUTION PREVENTION PLANS	
(SWPPPs)	39
12.1. INTRODUCTION	39
12.2. ORGANIZATION	39
12.3. ACCIDENTS OR INCIDENTS ON THE AIRPORT.....	40
12.4. USEPA GUIDANCE MANUALS	40
SECTION 1. PLANNING AND ORGANIZATION (PHASE 1).....	40
12.5. INTRODUCTION	40
12.6. POLLUTION PREVENTION TEAM.....	40
12.7. REFERENCING OTHER PLANS	41
12.8. SPECIAL REQUIREMENTS AND DUTIES.....	41

SECTION 2. ASSESSMENT (PHASE 2)	42
12.9. INTRODUCTION	42
12.10. DEVELOPING AN AIRPORT FACILITY SITE MAP	42
12.11. MATERIAL INVENTORY AND DESCRIPTION OF EXPOSED SIGNIFICANT MATERIALS.....	43
12.12. LIST OF PAST SIGNIFICANT SPILLS AND LEAKS.....	44
12.13. NON-STORM WATER DISCHARGES ASSESSMENT AND CERTIFICATION	45
12.14. STORM WATER MONITORING AND SAMPLING DATA.....	46
12.15. SITE EVALUATION SUMMARY	47
 SECTION 3. BEST MANAGEMENT PRACTICES (BMP) IDENTIFICATION (PHASE 3) .	48
12.16. INTRODUCTION	48
12.17. GOOD HOUSEKEEPING	49
12.18. PREVENTIVE MAINTENANCE PRACTICES	51
12.19. SPILL PREVENTION AND RESPONSE PROCEDURES FOR AIRPORT FACILITIES	51
12.20. SPILL PREVENTION AND RESPONSE PROCEDURES FOR AIRCRAFT FUELING/DEFUELING ACTIVITIES	52
12.21. SPILL PREVENTION AND RESPONSE PROCEDURES FOR GROUND VEHICLE FUELING	53
12.22. SPILL PREVENTION AND RESPONSE PROCEDURES FOR DEICING/ANTI-ICING ACTIVITIES	53
12.23. MATERIAL SUBSTITUTION	56
12.24. AIRCRAFT, GROUND VEHICLE, AND EQUIPMENT WASH WATER.....	56
12.25. AIRCRAFT, GROUND VEHICLE, AND EQUIPMENT MAINTENANCE AREAS...	56
12.26. LOADING/UNLOADING DOCKS AND STORAGE AREAS.....	57
12.27. SOIL EROSION AND SEDIMENTATION CONTROLS	58
 SECTION 4. PLAN IMPLEMENTATION (PHASE 4)	59
12.28. INTRODUCTION	59
12.29. EMPLOYEE TRAINING PROGRAMS	59
 SECTION 5. EVALUATION (PHASE 5)	60
12.30. INTRODUCTION	60
12.31. VISUAL INSPECTIONS	61
12.32. RECORDKEEPING AND INTERNAL REPORTING	62
12.33. REVISION OF SWPPPS.....	63
 SECTION 6. SPECIAL SWPPP REQUIREMENTS	63
12.34. INTRODUCTION	63
12.35. SPECIAL REQUIREMENTS FOR DISCHARGES THROUGH LARGE AND MEDIUM MUNICIPAL SEPARATE STORM SEWER SYSTEMS	64
12.36. SPECIAL REQUIREMENTS FOR SARA TITLE III, SECTION 313 REPORTING FACILITIES	64
12.37. SPECIAL REQUIREMENTS FOR SALT STORAGE PILES.....	65
 SECTION 7. GENERAL ADMINISTRATIVE REQUIREMENTS	65
12.38. INTRODUCTION	65
12.39. COMPLIANCE DEADLINES	65
12.40. REQUIRED SIGNATURES	66
12.41. DESIGNATING SIGNATORY AUTHORITY	67

12.42. CERTIFICATION STATEMENT REQUIREMENT 67

12.43. SARA TITLE III, SECTION 313 FACILITY PLAN CERTIFICATION REQUIREMENTS..... 67

12.44. AVAILABILITY OF SWPPPS FOR PUBLIC ACCESS 67

12.45. USEPA DIRECTOR REQUIRED SWPPP MODIFICATIONS..... 68

APPENDIX A. ACRONYMS AND RELATED READING MATERIAL..... 69

 A.1. ACRONYMS..... 69

 A.2. RELATED READING MATERIAL..... 71

APPENDIX B. FEDERAL PRIORITY POLLUTANT LIST 73

APPENDIX C. WORKSHEETS FOR SWPPPS 77

APPENDIX D. SAMPLE OF AN AIRPORT SWPPP 89

APPENDIX E. SAMPLE OF AN EMERGENCY PLANNING & COMMUNITY RIGHT-TO-KNOW ACT (EPCRA) SECTION 313 AIRPORT TENANT FACILITY SWPPP 113

LIST OF FIGURES

Figure 9 - 1. Neutralization (continuous method)..... 25

Figure 9 - 2. Neutralization (batch method)..... 25

Figure 9 - 3. Reverse Osmosis (RO)..... 27

Figure 9 - 4. Sequencing Batch Reactor (SBR) 28

Figure 10 - 1. Chromic Acid Recovery..... 32

Figure 10 - 2. Chemical treatment of chromium wastes 33

Figure 10 - 3. Chemical oxidation of phenols..... 34

Figure 10 - 4. Cyanide treatment 35

Figure 11 - 1. Air flotation treatment system..... 38

LIST OF TABLES

Table 12 - 1. Five phase approach for developing airport oriented SWPPPs 40

Table 12 - 2. Equipment to inspect 52

Table 12 - 3. Areas to inspect 62

Table 12 - 4. Visual Inspection Checklist..... 63

Table 12 - 5. USEPA general permit requirements..... 64

Table 12 - 6. Specific Section 313 Facility Controls 66

CHAPTER 1. INTRODUCTION

1.1. BACKGROUND. In 1973, the Federal Aviation Administration (FAA) published advisory circular (AC) 150/5320-10, *Environmental Enhancement at Airports - Industrial Waste Treatment*, to address the subject of industrial waste management at airports. The Multi Sector General Permit (MSGP) currently authorizes storm water discharges associated with industrial activity for most areas of the United States where the National Pollutant Discharge Elimination System (NPDES) permit program has not been delegated. The guidance in this AC is based on the MSGP, which is used in non-delegated states, and which may be adopted or adapted by delegated states. Subsequently in 1991 and 1997, AC 150/5320-15, *Management of Airport Industrial Waste*, was issued to provide additional guidance for waste management at airports and for the development of a Storm Water Pollution Prevention Plan (SWPPP) that focused on best management practices to eliminate, prevent, or reduce pollutants in storm water runoff associated with particular airport activities. At the present time, the United States Environmental Protection Agency (USEPA) will issue a notice of proposed rule making in November 2008 relative to the management of airport storm water. This advisory circular is in response to the USEPA regulation proposal. It is noted that the worksheets in Appendix C and the example SWPPP may be modified on the basis of the final USEPA regulation governing storm water runoff. Appendix A provides related reading material.

1.2. AIRPORT INDUSTRIAL WASTES. Although airports are not usually considered as industrial complexes, daily activities, such as aircraft and ground vehicle washing and cleaning, fueling operations, aircraft maintenance and repair work (including painting and metalwork), engine test cell operations; de/anti-icing operations, and ground vehicle maintenance, are all sources of airport industrial wastes. Wastes generated by these activities that are addressed by this AC are categorized as either industrial wastewater, hazardous or non-hazardous wastes.

1.2.1. Industrial Wastewaters. Industrial wastewaters are generated during aircraft and ground vehicle washing, aircraft maintenance and repair work, and de/anti-icing operations. It is recommended that renters or leasee holders on airport property whose facilities generate industrial wastewater other than that expected from airport operations also comply with Federal, state, and local waste management regulations. Industrial wastewaters may be recycled, reused or discharged for treatment to onsite airport treatment systems or to an offsite Publicly Owned Treatment Works (POTW) or, for certain types of waste, discharged without treatment to surface waters. Wastes may also be sent offsite to commercial waste treatment facilities. This is explained in detail in Chapter 8. Because of their characteristics, industrial wastewaters are generally more difficult to treat than sanitary (domestic) sewage and represent a potentially significant threat to surface and ground water quality.

1.2.2. Hazardous Wastes. Hazardous and non-hazardous wastes may be generated during ground vehicle maintenance, aircraft cleaning, fueling operations, aircraft maintenance and repair work, and engine test cell operations. Management of hazardous wastes must strictly follow the most current stringent Federal, State and local regulations governing treatment, storage, and disposal (TSD). Paragraph 2.1 defines hazardous wastes.

1.2.3. Non-Hazardous Wastes. Non-hazardous waste must be disposed of in accordance with the acceptable Federal, State and local practices; for example, the discarding of oily rags or rags containing paints or solvents.

1.3. INDUSTRIAL WASTEWATER REGULATIONS AND WATER QUALITY STANDARDS. As provided under Section 303 of the Clean Water Act (CWA), Federal regulations require that all States develop water quality standards which have been approved by the USEPA. These

standards, which impact airports, are reflective of the effects of various pollutants upon the ultimate designated uses of the receiving water and are intended to maintain water quality at a level that adequately protects those uses. Numerous sections of the CWA outline provisions for other Federal regulations to ensure that State water quality standards are achieved. Regulations that can affect airports include the NPDES program (Section 402), Effluent Limitations (Section 301), National Standards of Performance (Section 306), and Toxic and Pretreatment Effluent Standards (Section 307). Section 403 of the CWA also outlines provisions for ocean discharge criteria. In addition to these Federal regulations, State and local regulations may impose additional, more stringent, standards for the discharge of airport-generated industrial wastewaters. Airports are advised of the necessity to coordinate all planned airport industrial waste activities with these agencies prior to the implementation of any management programs.

1.4. HAZARDOUS AND NON-HAZARDOUS WASTE REGULATIONS. As provided under the Resource Conservation and Recovery Act (RCRA), Federal regulations require that all generators of hazardous waste, including airport facilities and airport lessees, follow specific procedures for the TSD of hazardous wastes. Under certain circumstances, materials that would ordinarily be considered hazardous are exempt from RCRA regulations when they are present in industrial wastewater that is discharged to a POTW.

1.5. DE/ANTI-ICING AND STORM WATER OCCURRING WASTES.

1.5.1. Regulations. Section 405 of the Water Quality Act of 1987 (WQA) added section 402(p) of the CWA, which directed the Environmental Protection Agency (EPA) to develop a phased approach to regulate storm water discharges under the NPDES program. The USEPA published a final regulation on the first phase on this program associated with industrial activity. EPA defined the term storm water discharge associated with industrial activity in a manner to cover a wide variety of facilities. The USEPA has implemented NPDES regulations for storm water discharges from transportation facilities, which specifically identify airport de/anti-icing operations. These regulations will require proper management of wastes generated by such operations. Regulators at the State and local levels have also begun to establish more stringent limits for de/anti-icing chemicals in storm water discharges. At this writing, the USEPA informed the FAA in February 2008 that they expect to release a Notice of Proposed Rule Making (NPRM) in November 2008 with a 120 day comment period. The objective of the Effluent Limitations Guidance for deicing discharges is to set minimum standards for managing discharges of deicing runoff that will be incorporated into NPDES permits held by all airports covered by the regulations. The USEPA plans to publish the proposed rule in 2008 and take final action in September 2009. A separate branch of the USEPA is charged with regulating storm water under the NPDES program. Most airports have an NPDES permit that regulates the discharge of storm water collected at the airport.

1.5.2. Planning Team. The regulations for proper management of airport-generated industrial waste will no doubt become more restrictive with time. In addition, other chemicals currently contained in water discharges from the airport may become subject to future regulation. Thus, it is recommended that airport operators confer with the airlines, tenants, and other involved parties to plan a comprehensive program for effective management of all current and expected future waste. Besides addressing the airport's site-specific and operational needs, this approach produces a unified program benefiting all parties. It is also recommended, in the planning of airport expansion or the designing of new airports, that airside drainage systems have the capability, when required, of channeling certain portions of or all airside runoff to specific locations for proper management.

1.6. DEVELOPING A STORM WATER POLLUTION PREVENTION PLAN. The process for developing a SWPPP is outlined in Chapter 12. The SWPPP identifies all potential pollutant sources and include descriptions of control measures to eliminate or minimize contamination of storm water. The

application of Best Management Practices (BMP) is an essential element of the SWPPP. The USEPA is expected to revise published BMPs for airport storm water in 2009.

Intentionally left blank.

CHAPTER 2. HAZARDS AND NUISANCES OF AIRPORT INDUSTRIAL WASTE

2.1. CHARACTERISTICS. The Federal regulations governing hazardous substances define a hazardous substance by the following characteristics: ignitability, corrosivity, reactivity, and toxicity. If a substance meets the thresholds outlined in RCRA regulations (40 Code of Federal Regulations (CFR) §261) then the substance may interfere with the POTW operation, or contaminate groundwater or contaminate surface waters.

2.1.1. Ignitability. Highly flammable liquids and vapors contained in some airport industrial wastes are fire and explosion hazards, particularly when discharged freely to sewers, natural bodies of water, or the ground. Vapors from volatile solvents, fuels, and oils may travel considerable distances in sewers and certain soils and form explosive concentrates in low, enclosed places. Wastes with a high solids content may cause deposits that form explosive gas during decomposition.

2.1.2. Corrosivity. Corrosive wastes can dissolve metals and other materials or burn human skin. Wastes generated during rust removal and acid or alkaline cleaning, as well as spent lead acid, lithium, and nickel-cadmium batteries, are corrosive wastes.

2.1.3. Reactivity. Wastes which are reactive are unstable or undergo rapid or violent chemical reaction with water or other materials. Wastes generated from cyanide plating operations and from processes involving oxidizers, such as bleaches, are reactive wastes.

2.1.4. Toxicity. Certain airport industrial wastes are toxic to human beings, livestock, and aquatic life, either by direct contact or through the contamination of water supplies. Pollutants contained in metal finishing wastes, such as cyanide and chromium, and certain organic compounds, such as degreasing solvents, are highly toxic at low concentrations in water. Mixed solutions of metal wastes can be much more toxic than simple solutions of corresponding or greater concentration. The formation of sludge deposits in streams by certain airport industrial wastes can create a potential health hazard to prospective users of the stream and restrict or prohibit its use for recreational or agricultural purposes.

2.2. INTERFERENCE WITH WATERWAY PURIFICATION OR POTW OPERATION. The discharge of airport industrial wastes to surface waters or to a POTW may have numerous adverse consequences. The airport operator should understand the potential for and establish measures and procedures to address situations where there would be adverse consequences due to the discharge of airport industrial wastes to such waters or facilities. This may include reviewing spill prevention and countermeasure plans and notifying facility authorities of potential problems.

2.2.1. Waterway Self-purification. The self-purification of waterways depends largely on a sufficient supply of oxygen to support the life and activity of fish and other aquatic organisms. Oils and greases form mats and slicks that hinder re-oxygenation of streams. Wastes with heavy organic loads will result in the consumption of dissolved oxygen when they biodegrade, and may form sludge deposits that could interfere with stream self-purification processes.

2.2.2. POTW Operation. Increases in the organic loading to a POTW may cause the total loading to exceed its headwork loading capacity; thereby, decreasing the plant's efficiency or violating the NPDES discharge permit. Suspended solids increase the demand on POTW sludge handling equipment and may hinder POTW sludge digestion. Emulsified oil and grease may adversely impact receiving waters. Toxic metals and toxic organic compounds may interfere with biological activity and may complicate sludge disposal. Acids and alkalis may corrode pipes, pumps, and treatment units and may interfere with settling and biological activity. Flammable materials may cause fires and may lead to explosions.

Noxious gases present a direct danger to worker's health and safety, while detergents may cause foaming in aeration basins. The use of aircraft deicing fluids both ethylene glycol (EG) and propylene glycol (PG) - based fluids may not be accepted by a POTW due to the high organic load impact. Wastes with heavy organic loads will result in the consumption of dissolved oxygen when they biodegrade and may form sludge deposits that could interfere with stream self-purification processes. These consequences also need to be addressed for onsite airport wastewater treatment plants.

2.3. CONTAMINATION OF GROUND WATER. Disposal of airport industrial wastes by land application may be constrained where there is the potential for ground water contamination. Future stringent groundwater regulations may have an impact on airport deicing operations and industrial wastes. These practices are generally unacceptable in areas where affected ground water is used as a source of drinking water.

CHAPTER 3. TYPES OF AIRPORT INDUSTRIAL WASTE

3.1. CLASSIFICATION. Proper classification of airport-generated industrial waste will assist the airport operator in implementing an effective airport waste management program. Once categorized, design alternatives for TSD can be planned in compliance with Federal, State, and local regulations. Airport industrial wastes are classified according to the pollutants they contain or the characteristics they exhibit. The classification includes industrial wastewaters, hazardous wastes and non-hazardous wastes.

3.1.1. Industrial Wastewaters. Industrial wastewaters are generally characterized in terms of conventional pollutants and priority pollutants. Conventional pollutants include oil and grease, total suspended solids (TSS), pH, and biochemical oxygen demand (BOD₅). The priority pollutant list is located in Appendix B.

3.1.2. Hazardous Wastes. A waste is considered to be hazardous if it appears on any one of the four lists of hazardous wastes contained in the most recent RCRA regulations (40 CFR §261), or if it has one or more of four characteristics: ignitability, corrosivity, reactivity, and toxicity. Toxicity is currently determined by the Toxicity Characteristic Leaching Procedure (TCLP). Specific testing protocols contained in RCRA regulations (40 CFR §261, Subpart C) are used to determine if an airport's waste has any of these procedurally defined characteristics. The primary responsibility for determining if a waste exhibits a hazardous characteristic lies with the waste generator.

3.1.3. Non-Hazardous Wastes. Should a material be determined not to be a hazardous waste, then the material should be disposed of in a responsible, reasonable manner for disposal. Such items include oily rags or a sludge that may be packaged for disposal in plastic bags or shipped to be recycled.

3.2. CYANIDES. Cyanides may be present in wastes generated during metal plating, steel hardening, rust prevention, and stain removal operations. The total cyanide concentration specified in ambient water quality criteria established by the USEPA to protect human health is 0.2 parts per million (ppm). Chapter 10 contains alternatives for management of wastes containing cyanides.

3.3. CHROMIUM COMPOUNDS AND TOXIC METALS. Chromium compounds may be present in wastes generated during chromium plating, bright dipping, copper stripping, and anodizing operations. Other toxic metals, such as copper, lead, and zinc, may be generated during metal plating operations. Chapters 9 and 10 contain alternatives for management of wastes containing chromium compounds and other toxic metals.

3.3.1. Implications for POTWs. Wastes containing these compounds above certain concentrations may be toxic to microorganisms utilized in biological treatment. Hexavalent chromium compounds generated by plating and anodizing operations are toxic to aerobic microorganisms utilized in the biological degradation of sewage. Chromium in the trivalent form has also been found to be detrimental to sludge digestion during waste treatment.

3.3.2. The toxicity of chromium salts, both trivalent and hexavalent, varies widely with the pH (acidity and alkalinity), temperature, and hardness of the receiving stream. The total chromium concentration specified in the ambient water quality criteria established by the USEPA to protect human health is 0.05 parts per million (ppm). The National Primary Drinking Water Standards for metals established by the USEPA limit total chromium to 0.10 ppm, cadmium to 0.005 ppm, and lead to 0.015 ppm. National Secondary Drinking Water Standards limit copper to 1 ppm and zinc to 5 ppm.

3.4. ACIDS AND ALKALIES. Acidic and alkaline wastes, generated during pickling and cleaning operations, can corrode metal and concrete sewer pipes. Acidic wastes interfere with sludge digestion and biological activity and are toxic to fish. The pH of the airport industrial wastes that are carried through sanitary sewers should be between 6.0 and 9.0. Where both acidic and alkaline wastes are involved, neutralization by mixing of the two may be sufficient to achieve a pH in this range. Preliminary investigation of the compatibility of wastes should be conducted prior to mixing. Chapters 5 and 6 contain alternatives for waste management.

3.5. ORGANIC SOLVENTS AND PHENOLS. These wastes, generated during paint application and removal and the cleaning of aircraft and ground vehicles, can create explosion and toxicity hazards, interfere with sewage treatment, and pollute potable water. Solvents also interfere with bacterial activity in sludge digestion. Solvents and phenols, in particular, produce objectionable tastes and odors in water supplies. The concentration of phenol specified in the ambient water quality criteria for toxicity protection of human health is 3.5 ppm. The concentrations of several common industrial solvents, specified in ambient water quality criteria for carcinogenicity protection of human health, are 0.00019 ppm for methylene chloride, 0.00094 ppm for 1,2-dichloroethane, and 0.0027 ppm for trichloroethylene. Chapter 10 contains design and treatment options for organic compounds. Chapters 9 and 10 contain alternatives for waste management.

3.6. OIL, GREASE, AND/OR DETERGENTS. Precautionary measures should be taken in the design of waste treatment facilities or disposal strategies when wastes contain oil, grease, and/or detergents. These wastes are generated during cleaning of aircraft and ground vehicles and in vehicle maintenance shop operations. Segregation of wastes containing oil and grease helps to avoid coating carrier systems and increasing the BOD₅. Oil and grease coatings will also interfere with the efficiency of the precipitants used for coagulation and flocculation of industrial wastes. The mixing of dirt with cleaning wastes increases emulsions and clogs small openings in treatment units unless screened out. The pH of detergent wastes, usually ranging from 9.0 to 10.8, should be lowered by treatment. Detergents may cause partial sludge flotation through release of carbon dioxide. Chapters 9 and 10 contain alternatives for waste management.

3.7. BATTERIES. Spent lead acid, lithium, and nickel-cadmium batteries are generated from routine ground vehicle maintenance. The acidity in high levels in batteries may have adverse impacts on ground water if the batteries are disposed of improperly. Unless recycled, spent batteries are hazardous wastes if they exhibit any of the characteristics noted in Chapter 2. Chapter 6 contains guidelines on hazardous waste management.

3.8. DE/ANTI-ICING CHEMICAL WASTES. For most airports, aircraft de/anti-icing operations generate more waste than pavement de/anti-icing activities. A major problem facing airport operators is the BOD₅ and COD loading from de/anti-icing wastes to receiving waters and wastewater treatment plants to ensure compliance with applicable permits and regulations. Airports should take appropriate actions to meet the Federal Deicing regulations expected in December 2009. Chapter 8 contains alternatives for waste management.

CHAPTER 4. SURVEYS FOR AIRPORT INDUSTRIAL WASTE

4.1. OBJECTIVES OF A WASTE SURVEY. The general objective of a waste survey is to determine the sources, characteristics, and volumes of wastes that are generated. The specific aim is to assist the airport operator in establishing a sound basis for the management of these wastes, including waste minimization, recycling, or elimination by process modification.

4.2. REQUIREMENTS OF WASTE SURVEY. Requirements of any waste survey planning include familiarity with the airport industrial processes used, operating schedules, sources of individual wastes, and, if one exists, the airport's industrial sewer system and treatment plant. In order for the survey results to be of maximum value to the airport operator, it is necessary to obtain data for a period of time which is sufficient in length to ensure that all waste-producing operations are surveyed.

4.3. FLOW MEASUREMENT. For continuously flowing wastewater streams, the flow rates of both individual and combined streams should be measured at representative points and expressed in standard units such as gallons per minute (gpm), gallons per hour (gph), or gallons per day (gpd). The method used by the airport operator to determine the flow rate will depend upon the magnitude of flow. Common metering devices include weirs, nozzles, flumes, and flow meters. For wastes that are generated on an intermittent basis, such as spent process baths, certain hazardous wastes, and deicing runoff generation rates can be determined from the disposal volumes and dates.

4.4. SAMPLING. Accurate sampling necessary for correct analysis of airport industrial wastes can be difficult because wastes are seldom homogeneous, e.g., their composition may vary widely over a period of minutes. Flow proportional samples are recommended where applicable. All samples collected should be preserved in the proper manner according to the latest Standard Methods for the Examination of Water and Wastewater and all Chain of Custody Sheets should be accurately and thoroughly completed by the sampler. Additionally, wastes frequently contain material in suspension as well as in solution.

4.4.1. Industrial Wastewater. For industrial wastewaters, grab or composite samples should be taken and properly preserved before analysis. The sampling operation should be as frequent as situation specific requirements dictate.

4.4.2. Hazardous Waste. For hazardous wastes, sampling to determine waste characteristics should initially be frequent (e.g., collection of several samples of wastes each time the waste is generated) and should subsequently be performed periodically (e.g., monthly, annually, or biannually) to confirm that waste characteristics have not changed.

4.4.3. Non-Hazardous Waste. Generally, once a waste is determined not to be a hazardous waste then responsible disposal practices should be used. These practices include bagging the waste for trash receptacles, or shipment of the waste to laundry facilities or recycling facilities for reuse.

4.5. ANALYSIS.

4.5.1. Industrial Wastewater. Wastewater constituents which are required to be sampled and analyzed are dictated by discharge permit limits that are applicable to the waste streams. Parameters which are typically monitored include BOD₅, Chemical Oxygen Demand (COD), dissolved oxygen (DO), pH, total solids (suspended and dissolved), effluent temperature, color, turbidity, and oil and grease. Where there is reason to be concerned about toxicity testing may be required for specific toxic pollutants such as those listed in Appendix B. The recommended reference for analytical procedures for wastewaters is the latest edition of Standard Methods for the Examination of Water and Wastewater.

4.5.2. Hazardous Waste. Methods for analysis of hazardous waste characteristics are specified in 40 CFR § 261 Subpart C of the RCRA regulations.

4.5.3. Non-Hazardous Waste. If waste is determined not to meet the criteria for hazardous waste, then the waste should be disposed of in a responsible manner, typically through common waste/refuse management disposal practices.

4.6. STORMWATER POLLUTION PREVENTION DEVELOPMENT ASSESSMENT. The SWPPP must identify, through assessment, all potential pollutant sources. A map of the industrial facility is essential showing the contributing areas to each drain and ultimately each storm water discharge point. The SWPPP should identify the manufacturing process and the inventory of all materials used and the potential exposure to storm water. The quantity of each material or chemical used should also be quantified. The document *Environmental Screening Checklist and Workbook for Airports and Tenant Operations, July 2000* provides an effective tool for the assessment of potential pollutant sources.

CHAPTER 5. MANAGEMENT STRATEGIES FOR AIRPORT INDUSTRIAL WASTE

5.1. MANAGEMENT STRATEGIES. Historically, waste management at most industrial facilities has used end-of-pipe systems for the treatment of wastewaters and other wastes. Costs of waste disposal, stringent regulations for hazardous waste management, and regulations that prohibit land disposal of certain wastes have caused attention to be focused on management strategies that reduce the total volume, toxicity, and/or mobility of toxic wastes. Source reduction, recovery, and reuse can significantly decrease or eliminate airport waste as well as an airport's operational costs for treatment and/or disposal. To determine the potential savings of these operational costs, a study should be made of industrial and hazardous waste management at the airport. This AC highly promotes the use of an Environmental Management system (EMS). A complete EMS would monitor inventory, pollutant streams, how to maximize the potential to reduce pollutant loading/toxicity and how to reuse/recycle to the maximum extent feasible and to keep all requirements on a regular cycle for evaluation and permit re authorization. The value of the EMS is not just in compliance but in the process that formalizes asking the questions regarding impacts to the environment and how to routinely plan for reduction.

5.2. SOURCE REDUCTION. A waste survey (see Chapter 4) is the first step an airport operator has in identifying source reduction opportunities. After determining the volume and composition of waste streams, information should be compiled on how and where the waste is generated, process efficiencies, disposal costs, and unaccountable material losses. Keeping the number of solvents to a minimum makes recycling easier and reduces hazardous waste management costs. Conduct all liquid cleaning at a centralized station to ensure solvents and residues stay in one area. Store drip pans for direct solvents in a solvent sink or tank for reuse. Use non-hazardous cleaners when possible. Use as little water as possible to clean spills, leaks, and drips. Reuse water if possible and prevent any process water from leaking into non-contact cooling water or storm water. Operate machinery at correct temperatures and flow levels and consider using automatic control and lock-out valves. Install automatic flow controls or multiple rinse tanks in a counter-current series system and use drag-out recovery techniques. Use sprays or mist to rinse off excess process solution and agitate the rinse bath to increase its efficiency.

Raw material substitution can reduce or eliminate the use of certain materials that are difficult or costly to treat or dispose of. Maintenance associated with materials' management should be designed to minimize the amounts of materials used and the wastes generated by industrial processes. Installation of more efficient equipment and improved process control, such as automated de/anti-icing blending equipment or involving employees, can reduce waste generation. Reduction of certain types of wastes can be achieved by installing equipment that performs the same function, for example, the use of an infra-red deicing facility in lieu of conventional deicing chemical application. Use detergent-based or water-based cleaning systems instead of organic solvent degreasers. Steam clean or pressure wash parts instead of using solvents.

5.3. RECOVERY AND REUSE. Recycling of materials that might otherwise be discharged as wastes can reduce an airport's waste treatment and disposal costs as well as the expense for raw materials. Examples of waste recovery and reuse that are particularly applicable to activities at airports are the recovery of paint solvents by distillation, the recovery of electroplating chemicals using dragout recovery tanks, and de/anti-icing chemicals for other non-airside uses, or for airside use, after retesting and reapproval. Sludges that meet the USEPA Biosolids criteria may be considered for beneficial use for uses such as:

- Farm land
- Forest land

- Public works projects
- Landscaping
- Land reclamation projects.

A typical recovery process to reclaim the glycol in runoff from aircraft deicing operations includes pretreatment to remove dirt and debris, nano-filtration to remove the high molecular weight additives and distillation to increase the concentration of glycol in solution. The performance based standards for aircraft deicing fluid indirectly limit the onsite reuse of glycols because all recovered product must undergo performance based recertification. The reuse of any glycol for aircraft or runway application must be recertified in accordance with the appropriate SAE AMS specifications.

5.4. TREATMENT. Once opportunities for source reduction and recovery and reuse are exhausted, waste treatment may be necessary to reduce the volume, toxicity, or mobility of waste prior to discharge or disposal. Some industrial wastewater treatment technologies available to the airport operator are discussed in detail in Chapters 9 and 10. Chapter 6 offers airport operators management guidelines for hazardous waste.

CHAPTER 6. MANAGEMENT OF HAZARDOUS AND NON-HAZARDOUS WASTE

6.1. HAZARDOUS WASTES. The requirements of the hazardous waste regulations established by the USEPA are presented in 40 CFR §261 through 270. Wastes that are hazardous and regulated under RCRA are classified as either listed or characteristic wastes.

6.1.1. Listed Wastes. Listed wastes are considered to be hazardous regardless of the concentrations of hazardous chemicals contained in the waste. Listed hazardous wastes consist of wastes from nonspecific sources (F codes, 40 CFR §261.31), from specific sources (K codes, 40 CFR §261.32), and from commercial products (U and P codes, 40 CFR §261.33). The P code wastes are considered acutely hazardous and are subject to further restrictions concerning empty container storage and usage and allowable weight limits for generation and storage.

6.1.2. Characteristic Wastes. If a waste is not listed, the generator, in this case an airport facility operated by the airport itself or a lessee, should determine if a waste exhibits any of the characteristics of a hazardous waste: ignitability, corrosivity, reactivity, and toxicity.

6.2. GENERATOR STATUS. According to the Hazardous and Solid Waste Amendments (HSWA), generators are organized into three tiers based on the total quantity of non-acutely hazardous waste generated in any calendar month.

6.2.1. Conditionally Exempt Small Quantity Generators (CESQG). CESQGs generate less than 100 kilograms (kgs) of hazardous waste and no more than 1 kg of acutely hazardous waste in any calendar month. Most airport facilities fall into this category the majority of the time.

6.2.2. Small Quantity Generators (SQG). SQGs generate between 100 and 1000 kg of hazardous waste and no more than 1 kg of acutely hazardous waste in any calendar month. Some airport facilities fall into this category.

6.2.3. Large Quantity Generators (LQG). LQGs generate 1000 kg or more of hazardous waste or more than 1 kg of acutely hazardous waste in any calendar month. Airport facilities that operate aircraft maintenance and repair shops and engine test cell operations may meet this criterion.

6.2.4. Monthly Variation in Status. The status of an airport facility can change on a monthly basis if the total quantity of waste generated changes. If the generator status changes, the airport facility is subject to all of the applicable hazardous waste regulations pertaining to the new generator status. Airport facilities that anticipate process changes or that experience fluctuations in waste generation, storage, or accumulation need to be aware of their new responsibilities if their generator status changes.

6.3. GENERATOR IDENTIFICATION NUMBER. Certain hazardous waste generators must have the 12 digit USEPA Identification Number to perform the requirements of 40 CFR Part 262.12. Identification numbers are required for persons that generate or manage hazardous waste, including small and large quantity generators, transporters, and treatment, storage, and disposal facilities. A USEPA identification number for each site that generates hazardous waste is necessary. Once the proper authority has been contacted, an USEPA Form 8700-12, Notification of Regulated Waste Activity, is sent. A USEPA identification number is issued for each location. Only SQG and LQG airport facilities are required to obtain a USEPA Identification Number for the transportation of hazardous waste. However, many hazardous waste transporters will not handle waste from an airport facility that does not have an Identification Number, regardless of their generator status. Also, because the status of a generator can

change based upon monthly hazardous waste generation, it is advisable for CESQG airport facilities to obtain a USEPA Identification Number.

6.4. ACCUMULATION TIME. Time and quantity limits are set for the accumulation and storage of hazardous wastes to minimize the amount of waste routinely accumulated onsite. The time and quantity limits have been set, however, so that facilities such as airports may accumulate enough hazardous waste to ship it economically offsite for treatment or disposal.

6.4.1. Accumulation by CESQG Airport Facilities. There is no time limit applicable to the accumulation of hazardous waste by a CESQG. If a CESQG airport facility accumulates 1000 kg or more of hazardous waste onsite; however, the generator loses the CESQG exclusion. All of the accumulated waste is subject to full regulation under 40 CFR §262.34(d) and must be sent to a designated facility within 180 days (270 days for transport over 200 miles).

6.4.2. Accumulation by SQG Airport Facilities. An SQG airport facility may accumulate hazardous waste onsite without a permit or interim status for up to 180 days (or 270 days if the waste must be transported over 200 miles) provided that the following conditions are met: 1) the generator does not accumulate 6000 kg or more of hazardous waste; 2) the waste is only accumulated in either containers or tanks; and 3) the generator complies with the requirements for personnel training, emergency procedures, preparedness and prevention, and the technical standards for accumulation units according to 40 CFR §262.34(d).

6.4.3. Accumulation by LQG Airport Facilities. An LQG airport facility may accumulate any quantity of waste onsite for up to 90 days without a permit or interim status provided the following conditions from 40 CFR §262.34 are met: 1) storage occurs only in tanks or containers (no impoundments); 2) tanks or containers comply with 40 CFR §265, Subpart I, Standards for Containers, and Subpart J, Standards for Tanks; 3) the generator does not accept shipments of hazardous waste generated from offsite sources; 4) waste is sent to a designated facility within 90 days unless the waste is treated and rendered non-hazardous within the 90 days; and 5) the generator complies with the requirements for Preparedness and Prevention and Contingency Plan and Emergency Procedures of 40 CFR §265.

6.4.4. Exceeding Time or Quantity Limits. If SQG or LQG airport facilities exceed the time or quantity limits noted above, then they are considered to be storage facilities and must obtain a storage permit (as discussed below) and meet all of the RCRA storage requirements according to 40 CFR §264, §265, and §270.

6.5. ACCUMULATION UNITS. Airport facilities are required to designate areas within its facilities where hazardous wastes are stored prior to disposal. Containers in this area should be clearly marked. The requirements for containers in which hazardous wastes are accumulated are as follows:

6.5.1. Accumulation Requirements for CESQG Airport Facilities. CESQG airport facilities are not subject to storage or accumulation requirements unless they change generator status due to the amount of waste accumulated onsite. Nevertheless, following the rules for LQGs and SQGs should minimize potential risks to both human health and the environment.

6.5.2. Accumulation Requirements for SQG Airport Facilities. SQG airport facilities accumulating hazardous waste in containers must comply with Subpart I of 40 CFR §265, except for §265.176, which requires ignitable (§261.21) and reactive (§261.23) wastes to be placed at least 50 feet (15.2 m) inside the facility's property line.

6.5.3. Accumulation Requirements for LQG Airport Facilities. LQG, CESQG and SQG airport facilities accumulating hazardous wastes in containers must comply with Subpart I of 40 CFR §265. The date when accumulation begins and the words "HAZARDOUS WASTE" must be clearly labeled on each accumulation unit. Tanks in which hazardous wastes are accumulated must be in compliance with the provisions of Subpart J of 40 CFR §265, except §265.197(c) and §265.200, including: 1) a one-time assessment of the tank system, including integrity test results; 2) installation standards for new tank systems; 3) design standards, including an assessment of corrosion potential; 4) secondary containment phase in provisions; 5) periodic leak testing if the tank system does not have secondary containment; 6) closure; and 7) response requirements regarding leaks, including reporting to the USEPA Regional Administrator the extent of any release and requirements for repairing or replacing leaking tanks.

6.5.4. Tank Accumulation Requirements for LQG and SQG Airport Facilities.

6.5.4.1. Tank Systems. LQG and SQG airport facilities accumulating hazardous waste in a tank must comply with the following requirements pertaining to tank systems: 1) treatment must not generate any extreme heat, explosions, fire, fumes, mists, dusts, or gases, damage the structural integrity of the tank, or threaten human health or the environment in any way; 2) hazardous wastes or reagents that may cause corrosion, erosion, or structural failure must not be placed in a tank; 3) at least 2 feet (0.6M) of freeboard must be maintained in an uncovered tank unless sufficient overflow containment capacity is supplied; 4) the containment system must have the capacity to contain 10% of the volume of containers (if they are, grouped together) or of the largest (or sole) container, whichever is greatest; 5) continuously fed tanks must have a waste-feed cutoff or bypass system; and 6) ignitable, reactive, or incompatible wastes must not be placed into a tank unless these wastes are first rendered non-ignitable, non-reactive, or nonflammable.

6.5.4.2. Inspection Timetables. The waste-feed cutoff and bypass systems, monitoring equipment data, and waste level must be inspected at least once each operating day. The construction materials and the surrounding area of the tank system must be inspected for visible signs of erosion or leakage at least weekly. At closure of the generating facility, all hazardous wastes must be removed from the tanks, containment systems, and discharge control systems. Owners or operators of 90-day accumulation tanks are not required to prepare closure or post-closure plans, contingent closure or post-closure plans, maintain financial responsibility, or conduct waste analysis and trial tests.

6.5.5. Satellite Accumulation. A generator may accumulate a total of 55 gallons (208 L) of hazardous waste or 1 quart (0.97 L) of acutely hazardous waste at or near any initial generation point. As soon as the 55-gallon (208 L) or 1-quart (0.97 L) limit is attained, the generator has up to three days to move that container to the regular storage area. As soon as the container is at the regular storage area, the applicable time limit starts. Satellite accumulation containers must be marked with the words "HAZARDOUS WASTE" or with other words that identify the contents of the containers (40 CFR §262.34(c)(1) and 40 CFR §261.33).

6.6. ONSITE TREATMENT AND DISPOSAL. Treatment in a tank or container without a permit or interim status is permissible provided that the airport facility maintains compliance with 40 CFR §262.34. Treatment occurs within the storage time limit for each type of generator status. An airport facility may not dispose of hazardous waste onsite unless a disposal permit has been obtained. Any airport facility desiring to store, treat, or dispose of hazardous waste in any manner not consistent with allowable methods previously described needs a permit as described in 40 CFR §270. Obtaining a permit to store, treat, or dispose of hazardous wastes onsite can be both costly and time consuming. The operator of such an airport facility can obtain a permit by: 1) notifying the USEPA or the appropriate State agency of hazardous waste activity; 2) completing Part A of the permit application; 3) complying with the interim

status standards described in 40 CFR §265; 4) completing Part B of the permit application; and 5) complying with the standards described in 40 CFR §264 and §266.

6.7. MANIFESTS.

6.7.1. LQG Airport Facility Requirements. An LQG airport facility transporting hazardous waste offsite or offering it for transportation must use the Uniform Hazardous Waste Manifest (UHWB).

6.7.1.1. General Procedure. The manifest must accompany the waste wherever it travels. Each individual involved in a shipment must sign and keep one copy. When the waste reaches its final destination, the owner or operator of the designated and permitted TSD facility signs the manifest and returns a copy to the airport facility operator to confirm receipt. A designated TSD facility must have interim status or a permit. The designated TSD facility signing the manifest accepts responsibility for that shipment and cannot ship the waste back to the airport facility or any other facility unless that facility is also classified as a designated facility. Although a facility may accept responsibility for a shipment, the airport facility operator retains liability under 40 CFR §107 of the Superfund Amendments and Reauthorization Act (SARA).

6.7.1.2. Followup. Each person involved in the movement, storage, or receipt of hazardous waste requiring a manifest must retain a copy of that manifest for at least three years. If an airport facility operator does not receive a copy of the signed manifest from the designated TSD facility within 35 days after the initial transporter accepted the waste, the airport facility operator must contact the designated facility to determine the status of the waste. If the airport facility operator has not received a signed manifest within 45 days, an exception report, which consists of a copy of the original manifest and a letter explaining the efforts taken to locate the waste and the results of those efforts, must be filed with USEPA.

6.7.2. SQG Airport Facility Requirements. An SQG airport facility must use the Uniform Hazardous Waste Manifest and retain copies of manifests for at least three years.

6.7.3. CESQG Airport Facility Requirements. A CESQG airport facility is not legally required to utilize a manifest for hazardous waste. However, many transporters will not handle waste from such facilities. Since airport facilities can change status based upon monthly changes in hazardous waste generation, it is advisable to recommend CESQG airport facilities to utilize manifests and retain copies.

6.7.4. Designating Storage, Treatment, or Disposal Facilities. Any type of storage, treatment, or disposal facility that an airport facility designates to receive hazardous waste must be either: 1) permitted or have interim status under §270 of RCRA; 2) authorized to manage hazardous waste by a State with an authorized program under §271 of RCRA; 3) permitted, licensed, or registered by a State to manage municipal or industrial hazardous waste; 4) a permitted facility that beneficially uses, reuses, or legitimately recycles or reclaims the hazardous waste; or 5) a permitted facility that treats the waste prior to beneficial use or reuse or conducts legitimate recycling or reclamation.

6.8. PERSONNEL TRAINING, PREPAREDNESS AND PREVENTION, AND CONTINGENCY PLANS AND EMERGENCY PROCEDURES. As specified in 40 CFR §262.34, a generator of hazardous waste is required to comply with the requirements of 40 CFR §265.16 (personnel training) and of Subparts C (preparedness and prevention) and D (contingency plan and emergency procedures) of 40 CFR §265.

6.8.1. Personnel Training for LQG Airport Facilities. LQG airport facilities must establish a training program for appropriate facility personnel designed to reduce the potential for errors that might threaten human health or the environment. This program must also include training to ensure facility compliance

with all applicable regulations. Both initial training and annual updates are required. Either on-the-job or formal classroom instruction is allowable; however, the content, schedule, and techniques used for on-the-job training must be detailed in the training records maintained at the facility.

6.8.2. Personnel Training for SQG Airport Facilities. SQG airport facilities must ensure that all involved employees are thoroughly familiar with proper waste handling and emergency procedures relevant to their responsibilities during normal facility operations and emergencies via generator-sponsored instruction. The training requirement is minimal compared to the more comprehensive instruction required for LQG airport facilities.

6.8.3. Personnel Training for CESQG Airport Facilities. CESQG airport facilities are not legally required to provide personnel training; however, it may be advisable to provide, at a minimum, the type of training required for SQGs, particularly given that generator status could change.

6.8.4. Preparedness and Prevention. Facilities that generate waste onsite must be in compliance with 40 CFR 265.1 (c) (7).

6.8.5. Contingency Plan and Emergency Procedures. Both LQG and SQG airport facilities must have a contingency plan, as outlined in Subpart D of 40 CFR §265, that is designed to minimize hazards in the case of a sudden or non-sudden release, fire, explosion, or similar emergency.

6.8.5.1. Plan Requirements. Such a plan must contain a description of actions that will be undertaken by facility personnel, a detailed list and location of emergency equipment, and evacuation procedures. Airport facility operators who have previously prepared a Spill Prevention, Control, and Countermeasures (SPCC) Plan in accordance with either 40 CFR §112 or §300, or some other emergency or contingency plan, need only to amend that plan to incorporate hazardous waste management provisions.

6.8.5.2. Personnel Requirements. There must be at least one employee either on the premises or on call (i.e., available to respond to an emergency at the facility within a short time) at all times with the responsibility of coordinating all emergency response measures (the emergency coordinator). The emergency coordinator, in responding to any emergencies that may arise, should institute the following emergency procedures, if appropriate: 1) contact the fire department and/or attempt to extinguish any fire; 2) contain any flow and commence cleanup wherever possible; and 3) notify the National Response Center of any fire, explosion, or release that meets a Superfund reportable quantity (40 CFR §302) or a release that threatens human health or the environment. The airport facility must post the name and telephone number of the designated emergency coordinator, the telephone numbers of the fire department and appropriate emergency response organizations, and the locations of fire extinguishers, spill control equipment, and fire alarms next to all appropriate facility telephones.

6.9. EMERGENCY PLANNING AND COMMUNITY RIGHT-TO-KNOW. In the fall of 1986, Congress passed the Emergency Planning and Community Right-To-Know Act (EPCRA). This law, which is Title III of the SARA, directs States, communities, and industry (e.g., airport facilities) to work together in order to plan for chemical accidents, develop inventories of hazardous substances, track toxic chemical releases, and provide public access to information relating to hazardous substances. Airport facilities that handle or use any of a list of extremely hazardous chemicals over certain quantities must notify public agencies that they are covered by the emergency planning provisions of Title III and must appoint representatives to provide detailed information to State commissions and local committees that will be used to prepare emergency preparedness plans. Both airport facilities and aircraft are treated as facilities under Section 40 CFR §304 (42 U.S.C. 11001). Only for the purpose of emergency notification, owners or operators of facilities must also notify the State's emergency response commission

immediately after an accidental release of an extremely hazardous substance that is over the reportable quantity established for that substance, as well as follow-up written reports for the release. Title III also requires facilities that make, store, or use certain chemicals to file reports with the State commission and local committees if the chemicals are present above certain thresholds. Facilities that are required to maintain material safety data sheets (MSDSs) under the Occupational Safety and Health Administration (OSHA) Hazard Communication (HC) Standard must submit the MSDSs or a list of MSDSs to State and local authorities. Annual chemical inventory forms must also be supplied to State and local authorities.

CHAPTER 7. AIRPORT INDUSTRIAL WASTES CONVEYANCE AND COLLECTION

7.1. CONVEYANCE SYSTEMS. Airport industrial wastes containing appreciable amounts of certain materials, such as heavy metals, solvents, sludges, oils, greases, acids, or alkalies, are typically segregated and treated prior to discharge to sanitary sewers or receiving waters. Several types of collection systems are available to airport operators.

7.1.1. Closed. Closed systems are commonly used for wastes and sanitary sewage. Separate conveyance systems are required for sanitary wastes and airport industrial wastes that require pretreatment.

7.1.2. Special. Special provisions, such as the use of holding tanks or ponds, need to be made for some incompatible wastes which cannot be discharged to sewers without danger of fire, explosion, or damage to the materials used to construct the sewer.

7.2. SEWER MATERIALS. In most cases, the materials used to construct sewers to convey airport industrial wastes are the same as those used for sanitary sewers. These materials include metal, plastic, and concrete. Acid wastes are particularly corrosive to these materials. Cooling of wastes with temperatures above 180°F (82°C) prior to discharge to the sewer helps to prevent possible damage to sewer joints. For the selection of piping and pumps, consideration during design should be given to the corrosive and other damaging effects of many wastes on concrete and metal. In many applications, plastic pipe is less vulnerable to attack and is often used in place of metal pipe.

7.3. COLLECTION SYSTEMS. Concentrated waste materials can be segregated in holding tanks or ponds prior to pretreatment. This is often the case when the quantities involved are large enough to cause operational difficulties if combined with the general waste flow. Materials for which collection systems are often used include: concentrated acids, concentrated alkaline solutions, cleaners, solvents, plating solutions, stripping solutions, cyanide wastes, phenolic compounds, and de/anti-icing chemicals. Wastes are released from the collection systems for treatment at times and rates most favorable to the airport's or community's treatment system operation.

Intentionally left blank.

CHAPTER 8. MANAGEMENT OF DE/ANTI-ICING CHEMICAL WASTES

8.1. GENERAL GUIDANCE. The Airport Cooperative Research Program (ACRP) funded by the FAA, developed ARCP Report #11, *Managing Runoff from Aircraft and Airfield Deicing and Anti-Icing Operations*, in response to a need the airport industry identified for planning guidelines to assist airport and aircraft operators in identifying and selecting best management practices (BMPs) for controlling aircraft and airfield deicing runoff. Aircraft operators are included in this target audience because of their role as key participants and stakeholders in any decisions that may affect aircraft safety or operations. This introductory section presents background on the origins and drivers behind this research project, describes the purpose and objectives of this document, and explains the structure of the planning guidance. Subsequent sections present guidelines for developing integrated deicing runoff management systems (Section 2), guidance for evaluating and selecting individual BMPs (Section 3), and fact sheets describing each of the BMPs (Section 4). ACRP Project Report #11 is available at - http://www.trb.org/news/blurb_browse.asp?id=136.

8.2. AIRCRAFT DEICING FACILITIES. The operation of off-gate aircraft deicing facilities is a proven effective means for managing sprayed aircraft deicing/anti-icing fluids that do not remain on the aircraft. In general, aircraft deicing facilities consist of a two or more deicing pads, a drainage collection system, and a wastewater storage facility. At some airport locations, airport operators employ the use of infra-red technology to reduce the quantities of ADFs sprayed to deice aircraft. It is noted that infra-red is only used during the deicing phase. The anti-icing of any aircraft still requires the spraying of an appropriate aircraft anti-icing fluid. For design of traditional and infra-red facilities, please see AC 150/5300-14, *Design of Aircraft Deicing Facilities*.

8.3. RUNWAY SURFACE CONDITION MONITORING SYSTEMS One effective mean of preventing unnecessary application of pavement deicing/anti-icing agents is using runway surface condition monitoring systems. These devices measure the change in pavement temperature with some units providing surface condition and atmospheric weather conditions. By enabling airport maintenance staff to monitor continuously runway surface conditions, maintenance staff can predict freezing conditions by tracking changes in pavement temperature and apply new or additional pavement deicers in a timely manner. See AC 150/5200-30 for surface condition sensor specifications.

8.4. LAGOONS AND RETENTION PONDS. Conversion of suitable unused airport land into lagoons or retention ponds permits collection of large volumes of glycol-based fluid waste from pavement surface runoff.

8.4.1. Capacity. The minimum design capacity handles at least the surface runoffs for winter months because microbial activity needed for biodegradation decreases during the winter season, plus incorporate additional capacity for the thawing periods. Required oxygen could be provided by mechanical aeration or photosynthesis, although there would also be a decrease in algal growth during cold weather. Capacity requirements can be reduced by continuous aeration that allows for faster biodegradation and, thus, earlier release of glycol-based fluid waste. Additionally, lagoons of this type could also stabilize and pre-treat glycol-based fluid waste prior to discharge to a wastewater treatment plant.

8.4.2. Configuration. An acceptable configuration for any retention basin is one that is easily defensible from a wildlife standpoint. Square or circular retention basins are not recommended as they are attractive to birds, and waterfowl will seek the safety of a pond's center to escape harassment activities. Hence, linear retention basins are recommended since they facilitate wildlife harassment and, if necessary, permit easier covering of the basin. As concentrated glycol is toxic to wildlife, covering

may be necessary to prohibit any wildlife use. Fencing is recommended whenever potentially hazardous compounds are stored in open areas.

CHAPTER 9. TREATMENT TECHNIQUES FOR INDUSTRIAL WASTEWATERS

9.1. GENERAL. Pretreatment is generally necessary to prevent the deleterious effects of acids, alkalies, oils, and greases on treatment units and on microorganisms utilized in biological treatment. The need for pretreatment is very application specific. The techniques used for treatment of industrial wastewaters may involve various physical, chemical, and biological unit operations, tertiary treatment, and other treatment technologies. The operator of any treatment facility should furnish operator manuals and basic employee training in the proper operation of the treatment facility.

9.2. PHYSICAL UNIT OPERATIONS. Techniques used for the physical treatment of industrial wastewaters include equalization, screening, comminution, grinder pumps, grit removal, sedimentation, and flotation.

9.2.1. Equalization. Equalization is typically one of the first operations in a treatment system and is used to reduce the temporal variation in wastewater flow or concentration.

9.2.2. Screening. Bar racks (also called bar screens) with relatively wide spacing of 1 to 1.5 inches (2.5 to 3.8 cm) are often used at treatment plants for protecting pumps and treatment units from damage and clogging by large solids, rags, and other debris carried by sewage or wastewater. Revolving drum or disk screens with 1/16-inch to 1/4-inch (1.6 to 6.4 mm) openings may be suited for preliminary treatment of wastes containing coarse solids.

9.2.3. Comminution. Comminutors are devices that are used to cut up solids contained in wastewater. The cut up of solids into a smaller, more uniform size improves downstream operations and processes and eliminates other operational problems. A comminutor may be found at an airport prior to an onsite treatment system.

9.2.4. Grinder Pumps. Grinders or macerators are sometimes provided in piping systems for shredding solids, rags, and other debris to reduce wear on downstream pumps.

9.2.5. Grit Removal. Wastes from maintenance and repair operations are likely to contain considerable amounts of grit as well as dirt and grease. Washing and steam cleaning are major sources of these waste components. Grit is objectionable because it can clog sewers and cause rapid wear on pumps and sludge removal equipment. It is also harmful when treatment systems include sludge digestion because it can accumulate in the digester and clog draw-off piping. Wastes containing an excessive amount of grit should be segregated and subjected to grit removal and treatment by means of a grit chamber prior to discharge to sewer systems, pumping stations, or waste treatment systems. A grit chamber is an enlarged channel or long tank placed at the influent end of the treatment plant. A properly designed cross section will retard the flow velocity just enough to promote the gravitational settling of heavier solids prior to their removal.

9.2.6. Sedimentation. Sedimentation, with or without chemical pretreatment, is used in connection with the treatment of most industrial wastes because it produces a substantial reduction in the suspended solids content. Sedimentation basins similar to those used for sanitary sewage treatment are used for the treatment of industrial wastes. Normally, mechanical sludge and scum removal equipment is utilized during the process.

9.2.7. Flotation. Suspended material, such as oil, grease, and other substances with a specific gravity less than that of water, tends to separate from water by floating. Fine particles and some flocculent material with a specific gravity greater than that of water tend to settle, but at a very slow rate. Flotation

may be employed to remove these materials and may be accomplished in simple gravity separators or in dissolved air flotation units.

9.2.7.1. Gravity Separators. Gravity oil-water separators are good processors for the treatment of wastewaters generated by activities producing large amounts of oily wastes. The American Petroleum Institute (API) Separator is an example of a gravity separator of proven usefulness for oil removal. It consists of a long, narrow, relatively shallow, baffled basin equipped with a continuous skimming and scraping mechanism. Generally, free-floating dispersed oil, which will coalesce rapidly, is readily separated from industrial wastewater in this type of basin. Emulsified oil that coalesces slowly, however, is not reduced appreciably and needs to be chemically treated to break the emulsion.

9.2.7.2. Dissolved-air Flotation. This method is used to remove oil and grease from airport industrial wastes and involves the production of many small air bubbles within the waste. These bubbles attach themselves to the suspended particles, causing them to float to the surface and be skimmed by mechanical means. The clarified water is removed from the flotation tank through submerged outlets. The efficiency of the process may be improved by the addition of flocculating chemicals, such as alum, activated silica, and polymers.

9.3. CHEMICAL UNIT OPERATIONS. Chemicals are added to industrial wastewaters to achieve neutralization, break up oil and grease emulsions, coagulate suspended or colloidal solids, oxidize cyanides, reduce chromium, and precipitate heavy metals.

9.3.1. Neutralization. Concentrated acidic or alkaline wastes normally require neutralization prior to discharge. When both types of wastes are available, mixing the two is advantageous, since only the excess acid or alkali requires further neutralization. Reactivity of the combined wastes should be evaluated prior to mixing waste streams.

9.3.1.1. Pickling Acids. Acid wastes from metal pickling and finishing operations usually present the greatest problems. The various acids used in the pickling process are sulfuric, nitric, hydrochloric, and phosphoric, with sulfuric acid being the most commonly used. Quick lime and hydrated lime are the alkaline neutralizing agents most commonly used.

9.3.1.2. Treatment Modes. Neutralization may be accomplished by either continuous or batch treatment methods (see figures 9-1 and 9-2). Neutralization is carried out by feeding lime slurry to the spent pickle liquor in a tank equipped with an agitator. Lime requirements are obtained from the "acid value" of the pickle liquor and the "alkaline value" of the lime as determined by chemical analysis. The sludge formed in the process is disposed of in a sanitary landfill or as a hazardous waste if its heavy metal content is too high. Hazardous waste management is discussed in Chapter 6.

9.3.2. Breakup of Oil and Grease Emulsions. Emulsions can be broken by acidification, the addition of alum or iron salts, or the use of emulsion-breaking polymers. The disadvantage of adding alum or iron is the large quantities of volume generated. The breaking of emulsions is a complex art and often requires treatability testing prior to developing a final process design.

9.3.3. Coagulation and Flocculation. Coagulation and flocculation are employed to remove suspended or colloidal materials from wastewater. Chemicals commonly used for coagulation include alum, ferric salts, and polymers. Equipment used for coagulation and flocculation often consists of a rapid-mix tank, in which chemicals and wastewater are mixed, and a flocculation basin, in which rotating paddles promote particle aggregation. The flocculated mixture is settled in conventional settling tanks.

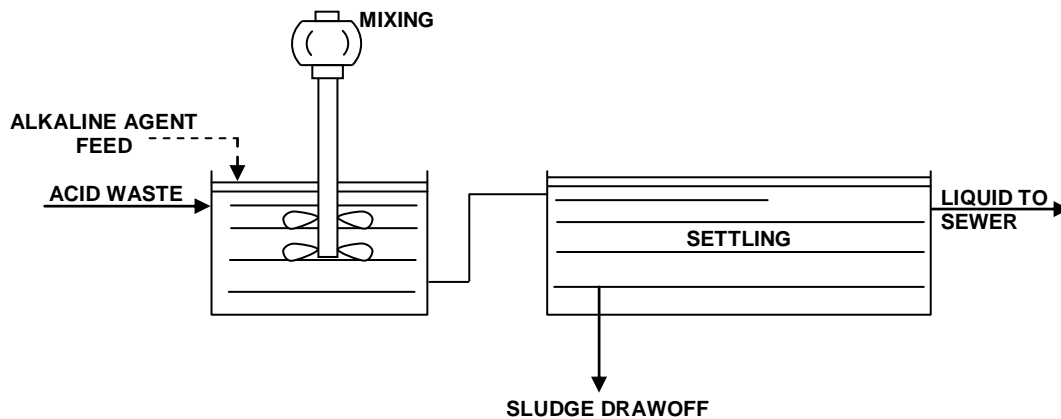

Figure 9 - 1. Neutralization (continuous method)

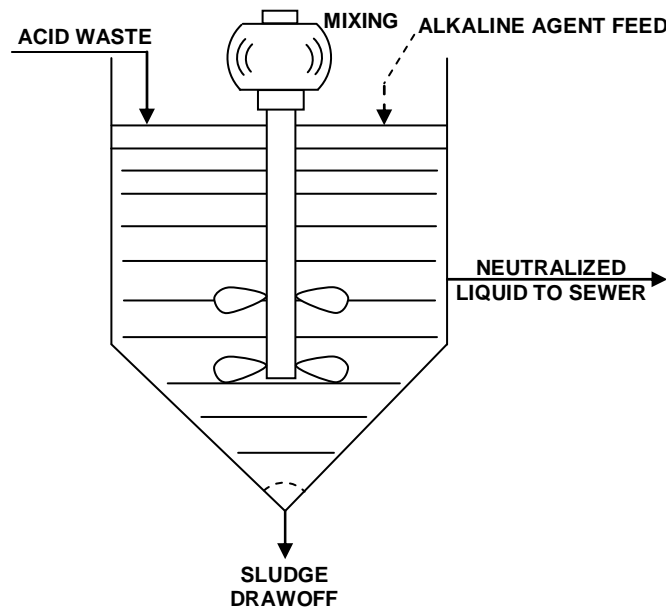

Figure 9 - 2. Neutralization (batch method)

9.3.4. Oxidation, Reduction, and Precipitation. At most airport facilities, oxidation of cyanides, reduction of chromium, and precipitation of heavy metals are treatment processes normally associated with electroplating operations. These technologies are addressed in Chapter 10.

9.4. MEMBRANE PROCESSES. Several membrane processes exist for the treatment of wastewaters which include ultra filtration and reverse osmosis (RO).

9.4.1. Ultra Filtration. Ultra filtration includes a group of membrane filtration in which hydrostatic pressure forces a liquid against a semi-permeable membrane. Suspended solids and solutes of high molecular weight are retained, while water and low molecular weight solutes pass through the membrane. This separation process is used in industry and research for purifying and concentrating macromolecular

(103 - 106 Dalton (Da)) solutions, especially protein solutions. Ultra filtration is not fundamentally different from RO, microfiltration, or nano-filtration, except in terms of the size of the molecules it retains.

9.4.2. Reverse Osmosis (RO). Reverse osmosis is a separation process that uses pressure to force a solvent through a membrane that retains the solute on one side and allows the pure solvent to pass to the other side. More formally, it is the process of forcing a solvent from a region of high solute concentration through a membrane to a region of low solute concentration by applying a pressure in excess of the osmotic pressure (see figure 9-3). This is the reverse of the normal osmosis process, which is the natural movement of solvent from an area of low solute concentration, through a membrane, to an area of high solute concentration when no external pressure is applied. The membrane here is semi-permeable, meaning it allows the passage of solvent but not of solute.

9.5. BIOLOGICAL UNIT OPERATIONS. The destruction of the organic component of many industrial wastes may be accomplished by biological degradation. Wastes which exhibit a biochemical oxygen demand are potentially amenable to biological treatment. Biological processes are usually employed after a substantial proportion of suspended matter has been removed.

9.5.1. Trickling Filters. Trickling filters, similar to those employed for domestic sewage, generally provide effective treatment of organic industrial wastes. Both standard and high-rate trickling filters with recirculation can be used. Trickling filters are reliable treatment devices which are relatively easy and inexpensive to operate and, in general, provide the best type of biological treatment for industrial wastes or for combined sanitary and industrial wastes.

9.5.2. Activated Sludge. The activated sludge process is useful for treating airport industrial wastes where the organic loading is relatively uniform or homogeneous. This method is sensitive to heterogeneous or shock loads and toxic substances and requires careful operating controls.

9.5.3. Aerobic Biological Treatment. In aerobic systems, organisms that respire oxygen grow on the wastes by breaking them down into carbon dioxide, water and new cell mass. Primary treated wastewater enters the aeration unit and mixes with dissolved oxygen and suspended and/or attached microbes. The aerobic microbes convert organic compounds into energy, new cells and residual matter. As the water moves through the clarifier, a portion of the biological solids are separated out of the effluent and are retained within the ATU. The biological solids settle back into the aeration chamber where they serve as seed for new microbial growth. Settled biomass and residuals will accumulate in the bottom of the chamber and must be removed with periodic maintenance. As the biomass creates an oxygen demand, clarification is an important part of generating a high-quality effluent. Many ATUs have a conical-shaped clarifier to promote separation of the biomass. As the cross-sectional area of upflow increases, the fluid velocity decreases. Once the settling velocity of the biomass is greater than the fluid velocity, the biomass will no longer move upward. During periods of no flow, the biomass will settle back into the aeration chamber. Other ATUs may incorporate in-line filters to separate the biomass from the effluent. Such filters require periodic maintenance to remove the build up of solids. In the aerobic process, organic nitrogen and ammonia are converted to nitrate. Under anoxic conditions (no molecular oxygen), the nitrate is denitrified to nitrogen gas. Some ATUs are designed to provide denitrification as part of their operation. Design modifications include intermittently supplying air and recirculating the nitrified wastewater into the anoxic regions within the treatment unit.

9.5.4. Anaerobic Treatment. In anaerobic treatment systems, microorganisms ferment the wastes to methane and carbon dioxide (CO₂) in the absence of oxygen. Anaerobic digestion is a bacterial process that is carried out in the absence of oxygen. The process can either be *thermophilic* digestion, in which sludge is fermented in tanks at a temperature of 55°C, or *mesophilic*, at a temperature of around 36°C.

Though allowing shorter retention time (and thus smaller tanks), thermophilic digestion is more expensive in terms of energy consumption needed for heating the sludge.

One major feature of anaerobic digestion is the production of biogas, which can be used in generators for electricity production and/or in boilers for heating purposes.

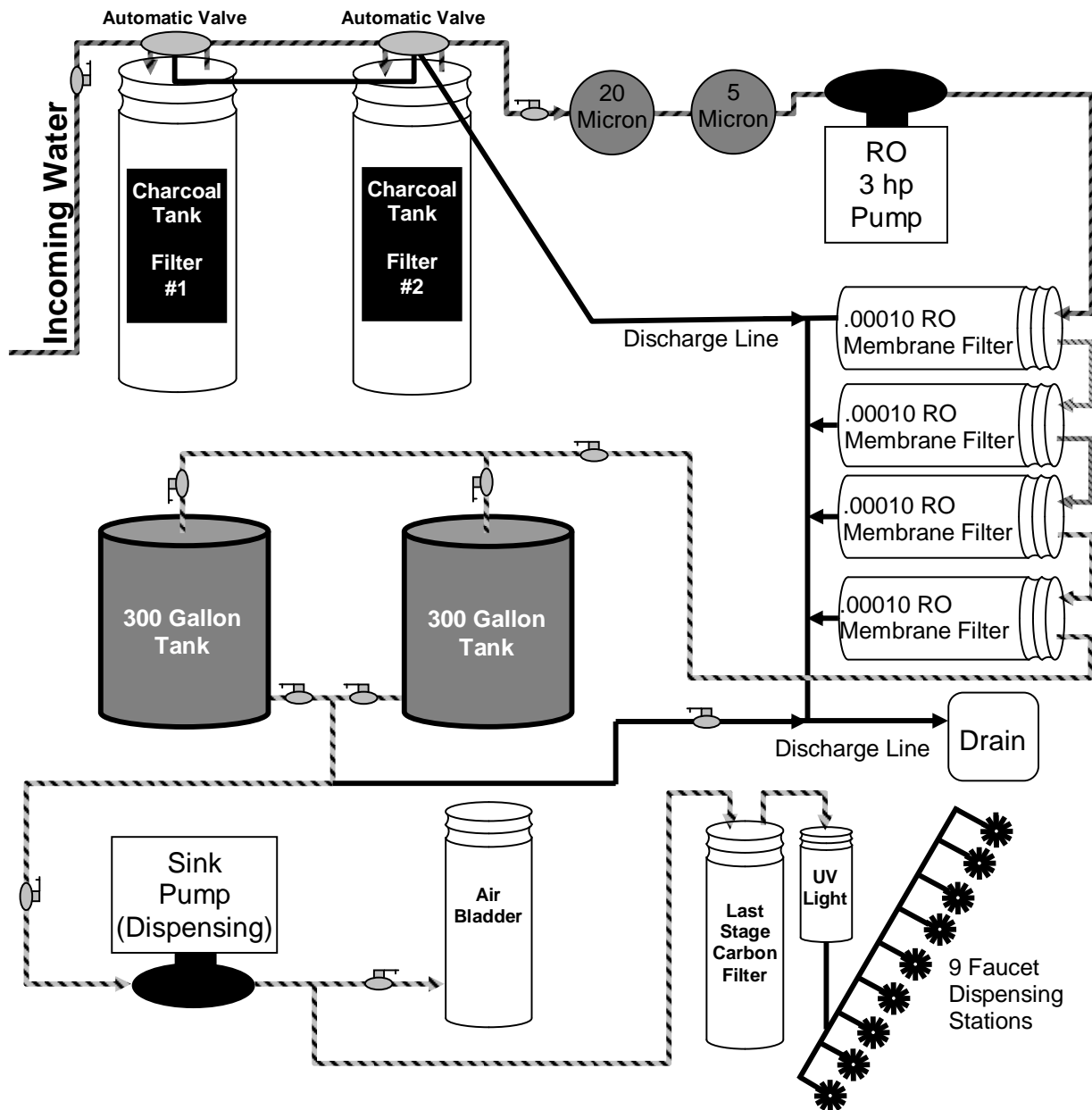

Figure 9 - 3. Reverse Osmosis (RO)

9.5.5. Sequencing Batch Reactor. Sequencing Batch Reactors (SBRs) or Sequential Batch Reactors are industrial processing tanks for the treatment of wastewater (see figure 9-4). SBR reactors treat wastewater such as sewage or output from anaerobic digesters or mechanical biological treatment facilities in batches. Oxygen is bubbled through the wastewater to reduce BOD₅ and COD to make

suitable for discharge into sewers or for use on land. The process includes filling, aeration, settling, and decanting.

While there are several configurations of SBRs, the basic process is similar. The installation consists of at least two identically equipped tanks with a common inlet that can be switched between them. The tanks have a “flow through” system, with raw wastewater (influent) coming in at one end and treated water (effluent) flowing out the other. While one tank is in settle/decant mode, the other is aerating and filling. At the inlet is a section of the tank known as the bio-selector. This consists of a series of walls or baffles which direct the flow either from side to side of the tank or under and over consecutive baffles. This helps to mix the incoming influent and the returned activated sludge, beginning the biological digestion process before the liquor enters the main part of the tank.

The aeration stage involves adding air to the mixed solids and liquid either by the use of fixed or floating mechanical pumps or by blowing it into finely perforated membranes fixed to the floor of the tank. During this period, the inlet valve to the tank is open and a returned activated sludge pump takes mixed liquid and solids (mixed liquor) from the outlet end of the tank to the inlet. This provides the incoming sewage with live bacteria. Aeration times vary according to the plant size and the composition/quantity of the incoming liquor but are typically 60 to 90 minutes. The addition of oxygen to the liquor encourages the multiplication of aerobic bacteria which consume the nutrients. This process encourages the production of nitrogen compounds as the bacteria increase their number, a process known as nitrification. To remove phosphorus compounds from the liquor, aluminum sulphate (alum) is often added during this period. It reacts to form non-soluble compounds, which settle into the sludge in the next stage.

The settling stage is usually the same length in time as the aeration. During this stage, the sludge formed by the bacteria is allowed to settle to the bottom of the tank. The aerobic bacteria continue to multiply until the DO is all but used up. Conditions in the tank, especially near the bottom, are now more suitable for the anaerobic bacteria to flourish. Many of these, and some of the bacteria which would prefer an oxygen environment, now start to use nitrogen as a base element and extract it from the compounds in the liquid, using up the nitrogen compounds created in the aeration stage. This is known as de-nitrification.

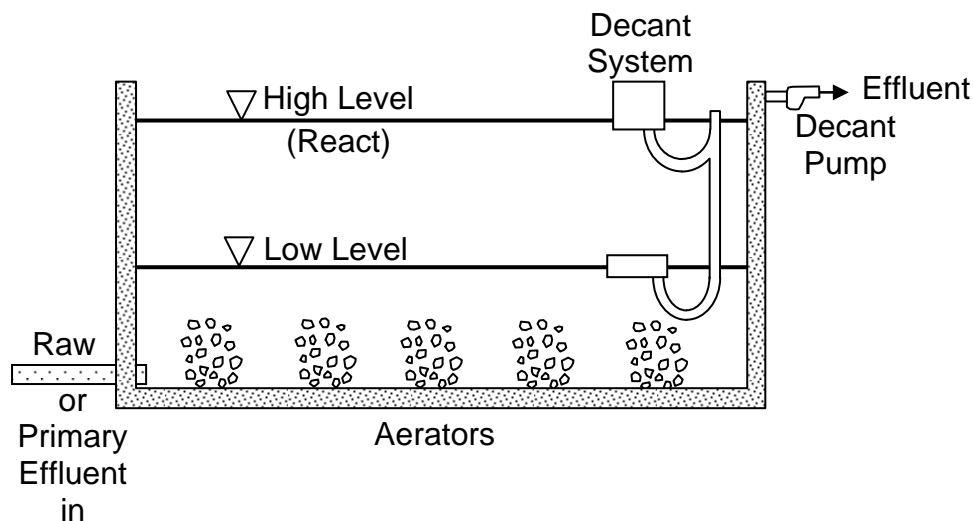

Figure 9 - 4. Sequencing Batch Reactor (SBR)

As the bacteria multiply and die, the sludge within the tank increases over time and a waste activated sludge pump removes some of the sludge during the settle stage to a digester for further treatment. The quantity of sludge within the tank is closely monitored, as this can have a marked effect on the treatment process. The sludge is allowed to settle until clear water is on the top 20%-30% of the tank contents.

The decanting stage most commonly involves the slow lowering of a scoop or trough into the basin. This has a piped connection to a lagoon where the final effluent is stored for disposal to a wetland, tree growing lot, ocean outfall, or to be further treated for use on parks, golf courses, etc.

9.5.6. Wetlands. Sub-surface flow wetlands are typically used where the wastewater being treated is noxious or odorous; where a higher degree of freeze protection is desired; where the attraction of wildlife (especially waterfowl) may be undesirable (e.g., at airports); and/or where ample, economic supplies of suitable substrate material are readily available.

These wetlands consist of submerged gravel beds constructed below ground level. To the untrained eye, they are difficult to discern from open fields. Technically, they are wetlands because wetland plants can grow in them, though there is no open water. Their water surfaces are typically 12 inches (30.5 cm) below their mulch and unsaturated gravel surfaces.

They can be operated either with the wastewater flowing horizontally through the bed or with the water percolating down vertically through the gravel. Bacteria attached to the gravel are responsible for pollutant removal. For high-strength deicing liquids, aeration of the bed is required to assist the bacteria in metabolizing the glycol.

Engineered wetlands are semi-passive constructed wetlands designed so that operating and process conditions can be modified, manipulated, and/or controlled, in contrast to the more passive operation of ordinary constructed wetlands. With engineered wetlands, higher levels of contaminant removals are possible at higher throughputs and with much shorter residence times. Constructed wetland systems can be “engineered” in many ways to improve performance greatly.

An aerated vertical subsurface flow (SSF) engineered wetland is one kind in which air (supplied by blowers) is introduced under thicker gravel substrate (4 – 12 feet (1.2 - 3.7M) thick). Aeration air flows up through the gravel from a buried fine bubble diffusion system, countercurrent to downward percolating wastewater. The vegetated gravel surfaces of engineered wetlands are insulated with layers of mulch or compost to prevent freezing problems, and the systems are designed to operate throughout northern winters — whatever the ambient air temperatures.

9.6. TERTIARY AND OTHER TREATMENT TECHNOLOGIES. Technologies used for tertiary treatment of industrial wastewater include: ion exchange, electrolytic recovery, air stripping, and adsorption.

9.6.1. Ion Exchange. In the ion exchange process, charged ions in the influent industrial wastewater are electrostatically attracted to ion-exchange resins to produce an effluent in which certain elements have been exchanged for others. The resins themselves are not altered chemically and can readily be regenerated, depending on the resin, by the use of a salt, base, or acid. This method is used to remove cyanides and chromates from rinse water, remove impurities from chromic acid plating and anodizing solutions, and produce demineralized water from raw water.

9.6.2. Electrolytic Recovery. In electrolytic recovery, industrial wastewater is subjected to a direct electrical current to achieve specific oxidation and reduction reactions in a manner similar to that employed in electroplating. By this method, heavy metals are removed from industrial wastewater by

plating them onto electrodes. Cyanide oxidation can also be accomplished by this technique. A major advantage to airport operators in using the electrolytic recovery technology for metal removal as compared to conventional treatment technologies, such as precipitation, is that little or no sludge generated by this method requires disposal as a hazardous waste.

9.6.3. Air Stripping and Adsorption. Air stripping and activated carbon adsorption are technologies commonly used for the removal of solvents and other toxic organic compounds from industrial wastewater. In air stripping, water is contacted with air in a countercurrent flow stripping tower which effects the partitioning of the organic compound from the water into the air. In activated carbon adsorption, wastewater is passed through a column packed with granular activated carbon. Organic compounds in the industrial wastewater are removed by adsorption onto the activated carbon. In some cases, bacterial growth within the pores of the activated carbon allows for biological degradation of organic compounds which extends the adsorption capacity of the activated carbon. Once its adsorption capacity is exhausted, the carbon is disposed of or regenerated in a furnace. The use of these technologies will probably increase in the future when more stringent discharge standards for toxic organics are developed and enforced.

9.7. TREATABILITY STUDIES. There is no standard method for treating industrial wastes, as each airport's industrial plant effluent presents a special treatment problem. Laboratory and pilot-plant studies may be required to determine the type of treatment required for a particular waste. Depending on waste characteristics, combinations of these basic procedures may be implemented to provide the required degree of treatment. Some treatability studies have been conducted for the treatability of glycol but the USEPA is still evaluating which technologies are best for airport waste.

9.8. SLUDGE HANDLING. With the exception of sludges that are either listed or characteristic hazardous wastes (e.g., sludges from electroplating or metal finishing that contain certain heavy metals or cyanides), organic sludge resulting from industrial waste treatment is dried and disposed of in the same manner as sanitary sewage sludge. Organic sludge may be handled by the digestion methods used in wastewater treatment facilities. Sludge drying may be accomplished on open beds, vacuum filters or the more common belt filter presses. Belt presses squeeze water out of the matter to form a cake of a certain percentage solids. The sludge cake is usually hauled offsite for incineration or land application. Industrial wastes containing large quantities of chemical coagulants generally produce a large volume of sludge that ordinarily does not dry as rapidly as sanitary sewage sludge.

CHAPTER 10. MANAGEMENT OF MAINTENANCE SHOP WASTES

10.1. GENERAL. The operations conducted at aircraft maintenance shops include cleaning, reconditioning, and overhauling aircraft. The principal wastes produced, in addition to those discussed in Chapter 11, are metal cleaning, treating, and plating solutions. This chapter describes treatment facilities for these major airport industrial wastes, including specific systems for the treatment of chromates and other heavy metals, phenols, and cyanides.

10.2. PLATING ROOM WASTES. Plating room wastes, which are mainly inorganic, consist of acids, cyanides, and heavy metals such as zinc, copper, lead, and chromium. The chief plating room operations contributing to the generation of these wastes are:

10.2.1. Stripping. The use of acidic or alkaline baths to remove undesirable films or coating on the metal to be plated.

10.2.2. Cleaning. The removal of oil, grease, dirt, and corrosion through the use of acidic and alkaline cleaners.

10.2.3. Plating. The process of using a direct electrical current to deposit metal on the material being plated produces metal and cyanide wastes.

10.3. SOURCES AND CHARACTERISTICS OF WASTES. The chief sources of wastes in plating room operations are: dragout losses (solutions carried out of the bath and into overflow rinses on the part being plated); spray losses (chiefly in chrome plating where the gas produced causes a fine spray); and the dumping of spent solutions. The characteristics of plating wastes vary considerably. They may be either acidic or alkaline, depending on the baths used. Chromate baths produce highly acidic wastes while alkaline cleaning baths and cyanides produce alkaline wastes. In general, plating wastes are highly toxic and corrosive.

10.4. PLATING WASTE REDUCTION. Dragout losses may be reduced by providing adequate drainage of the metal being plated and the use of a dragout recovery tank. Spray losses may be reduced by the installation of an exhaust system to recover finely divided spray for return to the solution tank. The use of series rather than parallel rinse tanks reduces water consumption. Drip pans to collect overflow solutions are recommended. Finally, good housekeeping and supervision decrease wastes, prevent improper dumping, and improve the segregation and collection of waste.

10.5. CHROMIC ACID RECOVERY. Streams containing chromates may be treated separately to remove contaminating metals from chrome plating and anodizing solutions. The contaminants are iron, trivalent chromium, copper in plating solutions and aluminum in anodizing solutions. A flow diagram of a chromic acid recovery system is shown in figure 10-1.

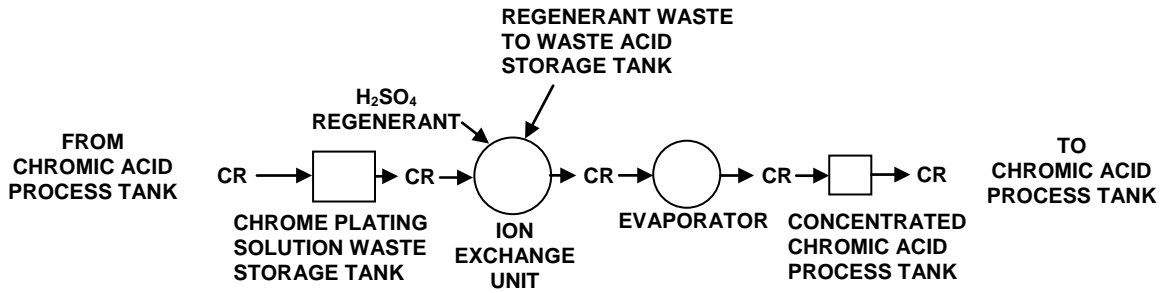

Figure 10 - 1. Chromic Acid Recovery

10.5.1. Waste Storage Tank. Spent chrome plating solutions from process tanks are collected in a storage or holding tank for dilution to a suitable chromic acid content. Anodizing solutions may be sufficiently low in chromic acid concentration and require no dilution. Dilution of plating solutions is necessary to avoid damage to the equipment used in the next step, ion exchange. The use of electronic equipment may help to regulate properly the amount of spent chromium at the proper concentrations to the storage tank.

10.5.2. Ion Exchange Equipment. A sulfonic cation exchange resin bed in the hydrogen form is used to exchange the contaminating metals in the solution with hydrogen ions in the resin bed. The purified solutions are then passed to an evaporator. When the accumulated impurities from the plating solutions inhibit the ability of the resin in the exchanger to continue purification, the exchanger is removed from service and the resin is regenerated with sulfuric acid. In the regeneration process, the sulfuric acid removes the contaminating metal ions and restores the exchanger resin to the hydrogen form. The sulfuric acid regenerant waste is treated by neutralization and precipitation.

10.5.3. Evaporator. The chrome plating solutions, which are diluted before passing through the cation exchanger to avoid excessive decomposition of the exchanger resin, are brought back to original concentrations by evaporation before return to the plating process tanks.

10.5.4. Chromic Acid Storage Tank. The purified and concentrated chromic acid is stored and returned to the plating process tanks as required.

10.6. CHROMIUM REDUCTION. Another method of treating chromate wastes is by the reduction of the chromate ion through the addition of ferrous sulfate, followed by neutralization with lime to precipitate heavy metals (see figure 10-2). Normally, batch treatment is used. The waste is discharged to acid-resistant tanks equipped with mixing devices, skimmers, baffled decanting outlets, and sludge withdrawal ports. Chemical doses for waste treatment are approximately twice the theoretical amount of either ferrous sulfur dioxide or barium. Following thorough mixing and a standing period of approximately one hour, oil and grease are skimmed from the top. Milk of lime is then added until the pH of the mixture is approximately 8.0. This mixture is then agitated and allowed to settle for a period of approximately 12 hours. The supernatant liquor is then decanted and the sludge removed.

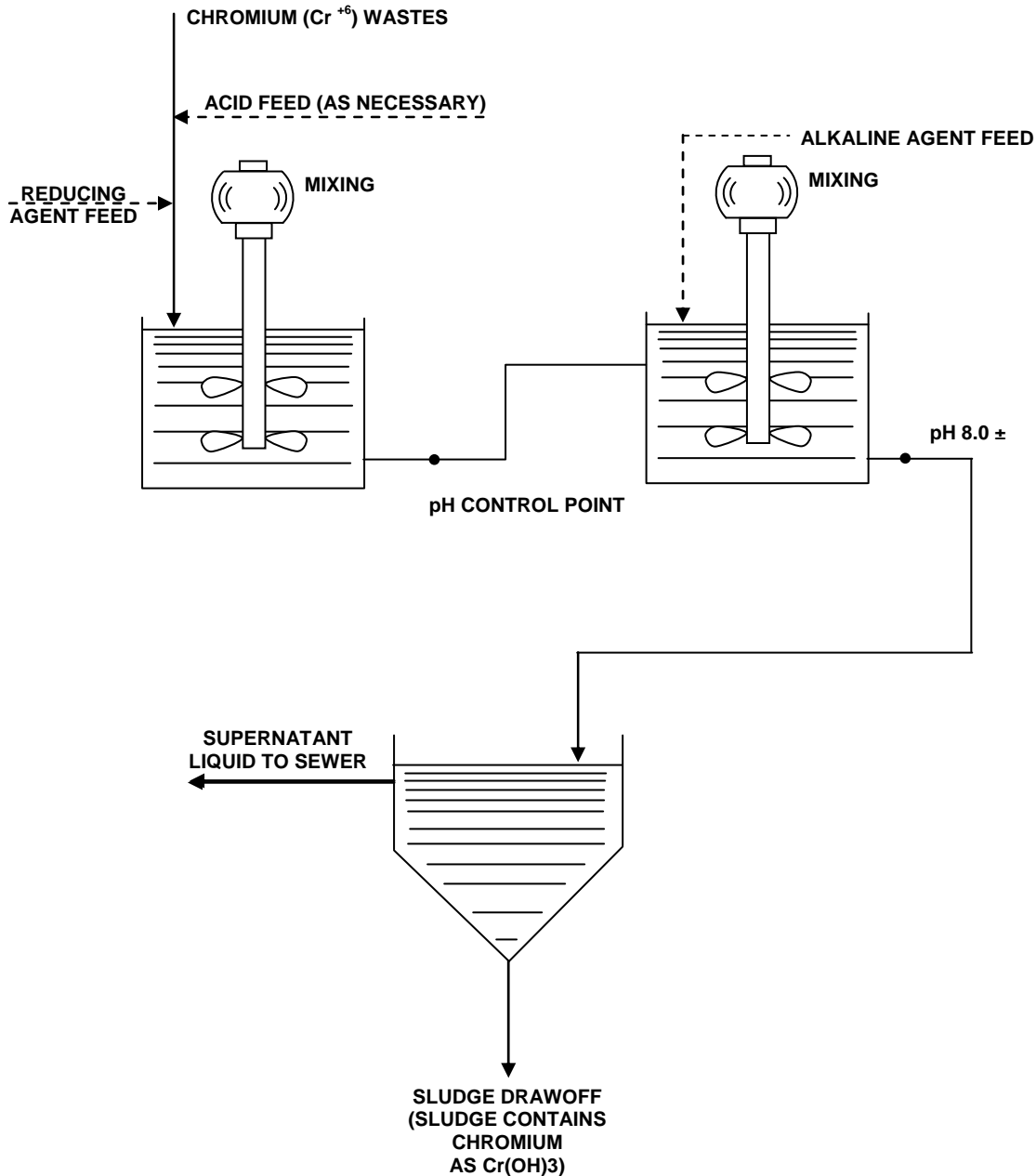

Figure 10 - 2. Chemical treatment of chromium wastes

10.7. PHENOLIC WASTES. Concentrated phenol and cresol wastes result from the cleaning of aircraft parts and require separate treatment. Biological treatment in sewage plants of wastes containing phenols and cresols has been used in some cases where the quantity of sewage is sufficient to dilute the phenols to a concentration of not more than 20 ppm. Pretreatment of phenol wastes for oils and suspended solids removal can be accomplished by the air flotation method previously described in paragraph 9.2.7.2.

10.7.1. Chemical Oxidation. Figure 10-3 shows a flow diagram of the system used for chemical treatment of phenolic wastes. Concentrated phenol and cresol wastes are collected in a receiving tank

with a capacity sufficient to hold at least the daily flow of these wastes. The tank contents are then transferred to the phenol oxidation tank where the pH of the phenol bearing wastes is raised by the addition of lime. Chemicals, such as alum or ferrous sulfate, are added to assist in coagulating the solids in the waste. The entire contents of the tank are then mixed and allowed to stand for a time to permit sludge and scum to separate out of the liquid. After separation, the scum and sludge are removed by oil skimming and sludge scraping mechanisms in the tank. Chlorine is added and the tank contents are thoroughly mixed to ensure complete oxidation of the phenols.

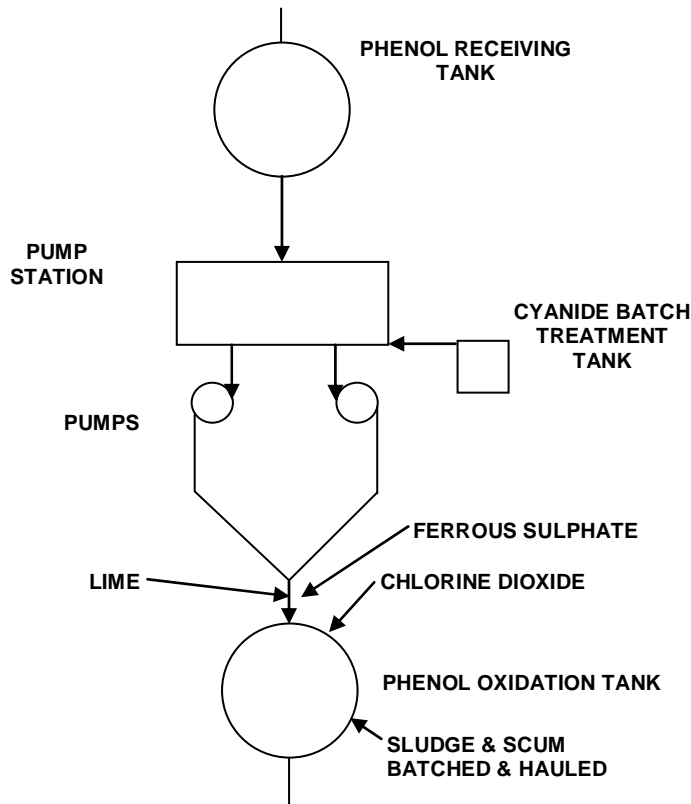

Figure 10 - 3. Chemical oxidation of phenols

10.7.2. Biological Treatment. Phenols at low concentrations (not greater than 20 ppm) can be treated by biological treatment processes such as trickling filters, the activated sludge process, or a combination of both. In these processes, the wastes, after neutralization with an alkali such as lime, flow to a primary sedimentation tank. The tank effluent flows through a two-stage trickling filter which removes a large part of the BOD₅ and phenol content. The effluent from the trickling filter is passed through aeration tanks in which further reduction of phenol content takes place. The effluent flow continues through secondary sedimentation units to remove biological flocs and other suspended materials. If necessary, the effluent flows to a holding pond for further retention before discharge to a stream.

10.8. CYANIDE WASTES. Cyanide wastes are normally treated by the alkaline chlorination method. While either batch or continuous treatment may be used, batch treatment facilities are best for small and medium-size plants.

10.8.1. Batch Treatment. In terms of waste management, batch treatment offers the advantage of positive control of effluent quality, since no wastes need to be discharged until analysis reveals complete cyanide destruction. Cyanide wastes are alternately collected in one of two holding tanks, each having

one day's capacity of waste flow. While one tank is filling, the contents of the other are being treated (see figure 10-4). Lime or caustic soda is added to raise the pH of the wastes above 8.5, and the pH is then continually maintained at this point by the addition of lime. A minimum pH of 8.5 is required to prevent formation of the toxic gas cyanogen chloride. After a thorough, vigorous mixing, chlorine is added for cyanide destruction. For small-scale operations, the chlorine is often applied in hypochlorite form. The approximate ratio, by weight, of the caustic and chlorine required to treat the cyanide is 10:1, with a minimum exposure period of one hour. Completion of reactions is assured by the application of a slight excess of chlorine.

10.8.2. Waste Release. After destruction of the cyanide, the alkaline wastewater may be mixed with other waste streams and used in neutralizing acid wastes.

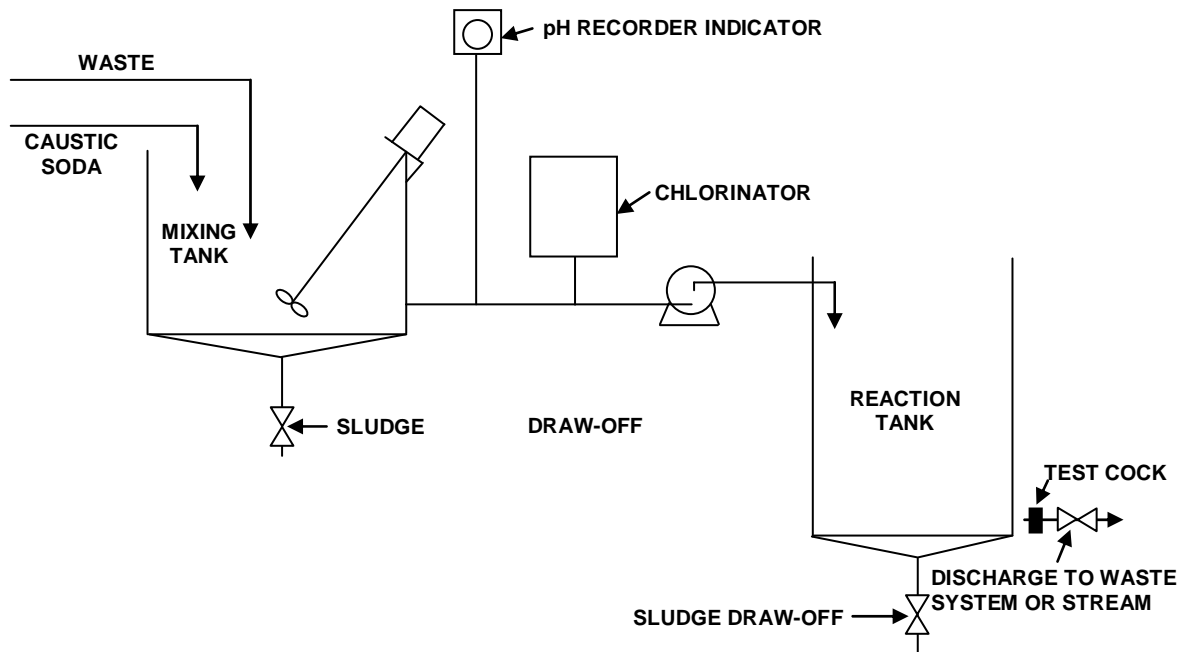

Figure 10 - 4. Cyanide treatment

10.9. PAINTING AND PAINT REMOVAL OPERATION. Facilities should not bury or discard waste paint cans, residuals, or unused paint products on site. Organic solvent-based paints and residuals may be classified as hazardous waste and may require manifesting, storage, transportation, and disposal in full compliance with RCRA (See Section 3.1.2 of this AC for guidance on hazardous waste and 40 CFR 262.34 for guidance on accumulation.). Paint cans (that once contained hazardous waste) that are classified as “empty” by the RCRA definition and latex paints may be recycled or disposed off site at an approved facility as non-hazardous waste.

Metal finishing processes are used to prepare the surface of a part for better adhesion, improved surface hardness, and improved corrosion resistance. Typical metal finishing operations include chemical conversion coating, anodizing, electroplating, and any operation that chemically affects the surface layer of a part. Each of these operations has the potential to significantly impact the environment by discharging metals, cyanides, phosphates, acids, and other contaminants to waterways, soil, or groundwater. Coating Application involves a material being applied to the surface of a part to form a decorative or functional solid film. The most common coatings are primers and topcoats. Facilities can apply coatings to aircraft components using several methods of application, which include spraying,

brushing, rolling, flow coating, and dipping. Nearly all coatings contain a mixture of organic solvents that must be disposed of properly.

10.10. OILY WASTES. Facilities should consider several environmental issues when performing any oil handling activities such as oil changes or oil/fuel filter replacement to motor vehicles, maintenance equipment, and other motors. Most facilities recycle or reclaim used oil. Used oils are regulated under the Used Oil Standards (40 CFR Part 279), and are typically not classified as hazardous wastes at the federal level. However, some states may have stricter disposal requirements. In addition, used oil generators are also subject to all applicable SPCC and underground storage tank (UST) standards. Contact the state regulatory agency to determine the used oil disposal requirements. Facilities should maintain all records on their used oil storage and recycling activities.

CHAPTER 11. MANAGEMENT OF AIRCRAFT WASHES AND SIMILAR WASTES

11.1. GENERAL. Discussion in this chapter involves the collection and treatment of wastes from aircraft wash racks, motor vehicle service areas, engine tests cells, engine repair shops, and other activities contributing large quantities of oil, grease, and emulsified wastes.

11.2. WASTE CONTRIBUTORS.

11.2.1. Aircraft Washing. In general, aircraft washing involves the following: 1) pressure spraying the entire aircraft surface with cleaning agents to loosen accumulated oil film, dirt, and oxides; 2) brushing the surfaces with an alkaline water-base cleaner to help loosen foreign matter; and 3) hosing down the surfaces with hot or cold water for thorough removal of emulsified oil, grease, and dirt from the aircraft.

11.2.2. Vehicle Service Areas. Vehicle maintenance wastes result from washing operations and the disposal of used grease and oil.

11.2.3. Engine Repair. Engine repair shop wastes result from cleaning engines and parts with alkaline cleaners.

11.2.4. Engine Test. Engine test cell wastes result from engine and floor cleaning operations and generally contain oil, grease, and emulsified materials.

11.3. AIRCRAFT WASH WASTES TREATMENT AND DISPOSAL. When large quantities of oil, grease, and emulsified wastes are being discharged, it may be necessary to use specifically designed treatment plants. A typical treatment plant consisting of a holding tank and air compression, chemical induction, and flotation units, is shown in figure 11-1 and described as follows:

11.3.1. Closed Loop. Many parts washers are closed loop and are self contained units. Typically, an outside contract service company is responsible for collecting and disposing of the parts washer tank wastewater.

11.3.2. Primary Treatment. Raw industrial wastes are piped to a combination holding tank and grit chamber. The tank is provided with devices for the removal of grit, free oil, and free solvent. Usually suitable stirring and mixing devices are installed to keep wastes from stratifying. This type of unit is called an oil/water separator.

11.3.3. Secondary Treatment. The secondary treatment system consists of a continuous operation of flocculation and flotation by air under compression. The components of the system are: inflow pumps, a chemical mixing tank, and mechanical sludge collection equipment for removing floated sludge from the liquid surface in the flotation tank to the sludge trough or hopper. Automatic controls are required for starting and stopping the operation of the inflow pumps at preset liquid levels in the surge tank.

11.4. SLUDGE DISPOSAL. Usually the sludge volume is approximately 10% of, the total flow when motor vehicle maintenance, engine test cell, and other wastes are included. Wet sludge is transferred to a storage basin where a three-phase separation occurs: the heavier sludge settles to the bottom; the lighter floating material forms a scum layer on the surface; and relatively clear water exists between the two layers. Sluice valves placed at various levels in the basin outlet structures may be selectively opened to draw off the clearest water for recirculation through the system. The accumulated sludge is periodically trucked away for proper treatment.

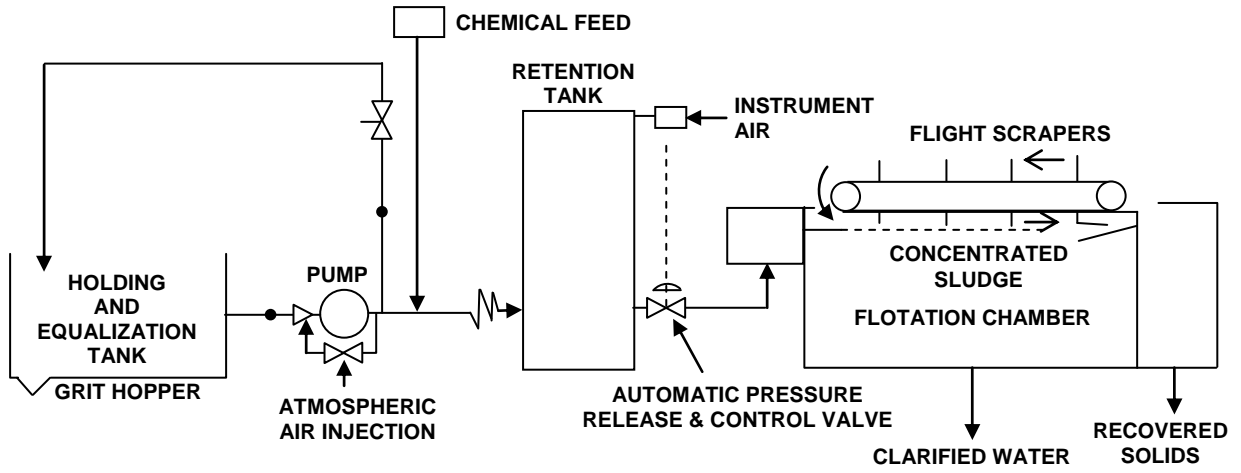

Figure 11 - 1. Air flotation treatment system

CHAPTER 12. AIRPORT-ORIENTED STORM WATER POLLUTION PREVENTION PLANS (SWPPPs)

12.1. INTRODUCTION. On November 16, 1990, the USEPA issued the final regulations regarding NPDES permits (40 CFR Parts 122-124) for storm water discharges from municipal and industrial activities. These regulations require the following identified industrial facilities permit holders to develop a SWPPP. The regulations are currently being revised and it is expected that the new Multi Sector Permit Program will be completed in 2008 or 2009. This guidance is based on the current USEPA's MSGP.

"Transportation facilities classified as Standard Industrial Classifications ... 45 ... which have vehicle maintenance shops, equipment cleaning operations, or airport deicing/anti-icing operations are regulated industrial activities. Only those portions of the facility that are either involved in vehicle maintenance (including vehicle rehabilitation, mechanical repairs, painting, fueling, and lubrication), equipment cleaning operations, airport deicing operations ... are associated with industrial activity."

12.1.1. Airport Oriented SWPPPs. SWPPPs require airport authorities to identify and implement schedules of activities, prohibitions of practices, maintenance procedures, and other management practices to eliminate, prevent, or reduce pollutants in storm water runoff from their site. This chapter emphasizes source reduction through the use of BMPs. The USEPA SWPPP guidance addresses the preparation of a SWPPP. Since the USEPA SWPPP guidance is general in nature, supplemental guidance based on aviation activities is provided to assist in the preparation of airport oriented SWPPPs.

12.1.2. Integration of Airport and Tenant SWPPPs. The USEPA or State permitting agencies holds airport authorities responsible for ensuring that the airport as a whole is in compliance with the permit conditions. Cooperative management efforts to manage similar airport and tenant generated pollutants can lead to lower compliance cost. Some additional strategies to improve compliance efforts are including BMPs and including a "right of entry" clause in tenant leases. This practice clearly emphasizes a tenant's critical role in the airport's compliance with the permit. In general, it is recommended that airport and tenant SWPPPs be integrated to provide more effective controls of storm water pollutants.

12.2. ORGANIZATION. A five phase approach to developing a SWPPP is shown in table 12-1, and review of the special SWPPP requirements described in section 6 is recommended.

12.2.1. Baseline Requirements of the General Permit. Sections 1 - 5 describe the "baseline" SWPPP requirements specified in the general permit and suggest options to address those requirements.

12.2.2. Special Requirements of the General Permit. Section 6 describes special requirements dealing with particular activities or other environmental regulations that some airport authorities may have to include in their plan.

12.2.3. Other General Permit Requirements. SWPPPs should include schedules for implementing activities and, where required by Federal, state, or local regulations, an identification of the signature authority.

Table 12 - 1. Five phase approach for developing airport oriented SWPPPs

Phase 1 - Planning and Organization
Phase 2 – Assessment
Phase 3 - BMP Identification
Phase 4 - Plan Implementation
Phase 5 – Evaluation/Monitoring

12.2.4. Authorized State and Local Requirements. Although in most cases state and local requirements will be similar to the Federal requirements, they may also be more stringent. Airport authorities should contact their state and local environmental authorities to determine additional requirements for their SWPPP.

12.2.5. Additional USEPA Requirements. Because of the multitude of airport activities, the Director of USEPA may develop additional permit requirements to reduce pollutants in storm water. When evidence of water quality problems associated with a specific airport activity exists, that activity may be regulated. In such a case, the airport SWPPP will need to be modified to address the activity.

12.2.6. Sample SWPPPs. Appendix C provides sample worksheets to organize information and implement plans. Appendices D and E provide samples of an airport SWPPP and an airport tenant SWPPP regulated as a Section 313 facility (see paragraph 12.36), respectively.

12.3. ACCIDENTS OR INCIDENTS ON THE AIRPORT. Vehicle or aircraft incidents or accidents can be sources of storm water contamination. To balance safety and environmental concerns, Airport Emergency Plans (14 CFR Part 139.325) should integrate follow-up containment and cleanup BMPs. *It is emphasized, however, that although spills resulting from incidents or accidents should be responded to, securing the well being of people comes first.*

12.4. USEPA GUIDANCE MANUALS. For a more comprehensive discussion on developing plans, please refer to USEPA 1992 guidance manuals, *USEPA 832-R-92-006, Storm Water Management for Industrial Activities: Developing Pollution Prevention Plans and Best Management Practices*, and *USEPA 832-R-92-005, Storm Water Management For Construction Activities: Developing Pollution Prevention Plans and Best Management Practices*. These manuals are available from the National Technical Information Service (NTIS), (703) 487-4650, and the USEPA Resource Center, (202) 260-7786 and are also found on the internet at <http://cfpub.epa.gov/npdes/pubs.cfm>.

SECTION 1. PLANNING AND ORGANIZATION (PHASE 1)

12.5. INTRODUCTION. This phase describes the starting point for the development of airport SWPPPs.

12.6. POLLUTION PREVENTION TEAM. The first step is to identify the individuals that will comprise the storm water pollution prevention team. Team members frequently include airport staff managers, supervisors of airport and tenant facilities, environmental managers, engineering personnel,

airfield maintenance personnel, etc. A senior manager should have overall responsibility for the plan. Worksheet No. 1 (see Appendix C) provides a means to list members and their information which should be displayed prominently at facilities so that employees can identify the proper contacts. This practice should allow for quicker corrective actions and potential reductions in cleanup and remediation costs.

12.6.1. Experience Level. The individuals chosen should have backgrounds that fit the type of activities or facilities subject to regulation. This correlation offers a better insight in understanding how an airport activity affects storm water and how to eliminate, prevent, or reduce resulting pollutants from entering storm water runoff. In return, greater opportunities exist to implement less costly, highly effective BMPs.

12.6.2. Basic Responsibilities. The basic responsibility of the team is to develop an airport SWPPP for airport compliance. After development, the team's responsibility shifts to ensuring implementation, maintenance, and revision. The team also should ensure that tenants develop, implement, and integrate their SWPPPs into the airport's SWPPP. Airport authorities should clearly define each member's area of responsibilities and duties. Some members may need signatory authority.

12.6.3. General Duties. Team members will perform initial site assessments, identify pollutant sources and their associated risks, identify BMP alternatives, implement their sections of the plan, and evaluate and monitor the effectiveness of the plan.

12.7. REFERENCING OTHER PLANS. Reviewing other airport plans and environmental plans to determine what provisions, if any, can be referenced, may streamline the development of a SWPPP. USEPA allows this practice provided referenced plans are available upon request, for instance, during site evaluations by environmental authorities. Regardless of the degree of reference, the airport SWPPP should be a stand alone, comprehensive document.

12.7.1. Airport Plans. Examples of airport plans that should be reviewed for potential reference are as follows: the aircraft fuel dispensing plan, temporary erosion control measures in construction plan (reference Item P-156, Temporary Air and Water Pollution, Soil Erosion, and Siltation Control, AC 150/5370-10, *Standards for Specifying Construction of Airports*), airfield daily inspection plan, airport emergency plan, and the snow and ice control plan.

12.7.2. Other Environmental Plans. Other environmental plans worth reviewing for reference are as follows: Preparedness, Prevention, and Contingency Plan (40 CFR Parts 264 and 265), Spill Prevention Control and Counter Measures Requirements (40 CFR Part 112), Toxic Organic Management Plan (40 CFR Parts 413, 433, and 469), and OSHA Emergency Plan (29 CFR Part 1910).

12.8. SPECIAL REQUIREMENTS AND DUTIES. When a tenant is subject to reporting requirements under the EPCRA Section 313 (also known as Title III of the SARA of 1986) for water priority chemicals, special requirements from that program become part of the airport SWPPP. Paragraphs 12.14, 12.18, 12.29, 12.36, and 12.43 (from paragraph 2.7.2 of USEPA 832-R-92-006) provide airport authorities those special requirements which should be addressed either in the plan or in a separate plan developed by the tenant. Furthermore, permits require the integration of this type of tenant plan with the airport SWPPP.

12.8.1. Designated Member. If a reporting facility exists, the airport authority should list in their plan a member accountable for spill prevention of regulated Section 313 facilities.

12.8.2. Specific Responsibilities. Specific responsibilities for the designated individual include, at a minimum, setting up necessary spill emergency procedures and reporting requirements to isolate, contain, and clean up spills and emergency releases of regulated Section 313 water priority chemicals before a discharge can occur.

SECTION 2. ASSESSMENT (PHASE 2)

12.9. INTRODUCTION. This phase focuses on identifying and assessing the impact of actual and potential pollutant sources that can contaminate storm water runoff. Worksheet No. 7 provides a means to record pollutant sources and related management practices.

12.9.1. Identifying Pollutant Sources. Team members should identify activities and significant materials resulting from current management practices and airport activities which can be sources of significant pollution. The review process should consider both wet and dry weather conditions since pollutant sources can discharge from storm water conveyances that drain airport and tenant facilities during either condition. To improve the selection of low cost, effective BMPs, plans should contain a brief description of how those sources add pollution to storm water discharges. Depending on the negotiated permit, plans may need to include regulated parameters for specific pollutant sources, e.g., 5-day biochemical oxygen demand (BOD₅) of aircraft deicing/anti-icing fluids.

12.9.2. Additional SWPPP Items. Depending on site specific conditions, plans may need to include information about the following:

- **Significant materials** (see paragraph 12.11.1) exposed to precipitation.
- **Regulated tenants** and their industrial activities and significant materials exposed to precipitation.
- **Past major spills or leaks.**
- **Unauthorized non-storm water discharges** (see paragraph 12.13).

12.10. DEVELOPING AN AIRPORT FACILITY SITE MAP. An airport facility site map that contains complete information on activities that pollute storm water discharges is an essential part of any SWPPP. Worksheet No. 2 lists the minimum details to include on the site map.

12.10.1. Locating Outfalls. Along with airport facilities, tenant facilities, and the airport property line, all airport storm water outfalls (these conveyances for point source discharges are also termed discharge points), where storm water enters a receiving body of water or a municipal storm sewer system, should be identified. For the latter case, the onsite drainage point to the municipal storm sewer system is considered the storm water outfall.

12.10.2. Receiving Bodies of Water. Site maps should identify receiving bodies of water, such as rivers, streams, ponds, and lakes, on or adjacent to the airport with their legal name whenever possible.

12.10.3. Delineating Drainage Areas. The site map should depict all drainage areas and direction of flows that supply each outfall. This can be done by working backwards from each outfall to airport and tenant facilities.

12.10.4. Airport Activities Within a Drainage Area. Fundamental to the delineation of potential pollution sources is the identification and the location within drainage areas of contributing pollutants or exposed significant materials that may contaminate storm water runoff discharging at the outfall(s). Past spills and leaks should also be located on the site map. The site map should describe and locate activities exposed to precipitation that are considered to be high risk waste generating areas and potential pollutants of storm water runoff. Potential high risk waste generating areas include the following:

- aircraft, vehicle, and equipment maintenance and cleaning areas,
- aircraft and runway deicing/anti-icing areas,
- material storage areas,
- loading/unloading docks,
- areas abutting runway maintenance activities,
- aircraft servicing areas, and
- airport and vehicle fuel systems, fueling areas, and fuel farms.

12.10.5. Structural Drainage Controls. The site map should identify and briefly describe drainage controls that direct or treat storm water runoff. These include storm drains, culverts, berms, open channels, subsurface drains, flow diversion boxes, and detention/retention ponds.

12.10.6. Soil Erosion and Sedimentation Controls. Site maps also should identify areas having potential for significant soil erosion and sedimentation due to airport activities, topography, or other factors. The site map should briefly depict stabilization or vegetative controls used to limit such problems (see paragraph 12.27 for additional information). Airports should develop airport wide appropriate, local, native seed specifications that are less attractive to flocking birds, while being easily maintainable.

12.11. MATERIAL INVENTORY AND DESCRIPTION OF EXPOSED SIGNIFICANT MATERIALS. Each facility should inventory the types of materials handled, stored, or processed onsite. SWPPPs require an inventory of materials at airports that may be exposed to precipitation in the past three years. The more comprehensive the inventory, the more likely the plan will identify all potential sources of contamination. Worksheet No. 3 provides a means to inventory materials, describe their location and quantities, and narrate handling, storing, and disposal practices. Worksheet No. 3A provides a means to inventory materials that have been exposed to storm water in the past three years and/or are currently exposed. Worksheet No. 3A should be included in the SWPPP.

12.11.1. Significant Materials. Of the materials identified, USEPA places special emphasis on materials defined as *significant materials* (40 CFR Part 122.26(b)(12)). Significant materials commonly found at airports include fertilizers (phosphorus and nitrogen), pesticides, herbicides, organic solvents and phenols, toxic metals from maintenance activities, sand, salt stockpiles (see paragraph 12.37 for special requirements regarding salt stockpiles), fuels, detergents, aircraft and runway deicing/anti-icing products, and chemicals used by tenants regulated under SARA Title III, Section 313 (see paragraph 12.36 for special requirements). The SWPPP should include narratives regarding significant materials which have been handled, treated, stored, or disposed of in a manner that allowed exposure to storm water between the time of three years prior to the date of the issuance of the permit and the present. It should also include the location and method of onsite storage and/or disposal of significant materials.

12.11.2. Management Practices Regarding Materials. Plans should include brief narratives of the management practices used to prevent exposed materials from coming into contact with storm water between the time of three years prior to the date of the issuance of the permit and the present. Inadequacies should be identified and rectified by considering activity-based practices, instead of structural-based practices, to reduce the cost of environmental compliance. For example, regularly scheduled sweeping, end of day inspections, or improved handling of products are less expensive than installing and maintaining storm water devices such as an oil/water separator.

12.11.3. Treatment Practices of Materials. Plans should include brief narratives of any treatment or pretreatment of materials released into storm water runoff. Treatment considerations include how to eliminate material exposure, directing material runoff away from storm water collection systems or a storm water conveyance (prevention), and reducing the quantities of materials on hand. AC 150/5220-18, *Buildings for Storage and Maintenance of Airport Snow and Ice Control Equipment and Materials*, provides guidance for the storage of deicing/anti-icing products and other materials.

12.12. LIST OF PAST SIGNIFICANT SPILLS AND LEAKS. Plans should include a list of significant spills and leaks of toxic or hazardous chemicals that have occurred on airport property within three years prior to the effective date of the permit. Worksheet No. 4 provides a means of doing this. Areas on the airport where significant spills or leaks have occurred should receive special examination when identifying BMPs. During the term of the permit, the list should be updated as necessary. Plans should include spill prevention and response procedures to reduce the likelihood of future spills or leaks, and thereby, lower cleanup and remediation costs.

12.12.1. Definition of Significant Spills. USEPA defines significant spills to include releases within a 24-hour period of hazardous substances in excess of reportable quantities. Reportable quantities, listed in 40 CFR Parts 117 and 302, are set amounts of substances in pounds, gallons, or other units. Examples of regulated substances are solvents from vehicle maintenance shops, waste metals from aircraft plating processes, and chemicals under Section 311 of the CWA (40 CFR Parts 110.10 and 117.3) or Section 102 of the Comprehensive Environmental Response, Compensation, and Liability Act (CERCLA) (40 CFR Part 302.4).

12.12.2. Definition of Releases. USEPA defines releases to include any spilling, leaking, pumping, pouring, emitting, emptying, discharging, injecting, escaping, leaching, dumping, or disposing into the environment.

12.12.3. National Response Center. As soon as possible, airport authorities and tenants should report releases of regulated hazardous substances in excess of reportable quantities within any 24-hour period to the National Response Center at 1-800-424-8802.

12.12.4. Hazardous Waste Material Management. Airport authorities' responsibilities, with respect to hazardous wastes generated on the airport, are outlined in Chapter 6. Issues discussed include USEPA requirements for generator identification number to transport hazardous waste off the airport, tank storage, Uniform Hazardous Waste Manifests, employee training, contingency plans, and emergency procedures.

12.12.5. Recording Deicing/Anti-icing Activities. Recordkeeping requirements of the plan for deicing/anti-icing activities are defined in Part III, B.2, Multiple Anticipated Discharges, of the general permit.

12.12.5.1. Release Records. The hazardous material release record should include the date, type, estimated amount of material released, and a description of the circumstances leading to the release.

12.12.5.2. Identified Measures. Plans should identify the implemented BMPs used to eliminate, prevent, or reduce such releases to storm water runoff.

12.12.5.3. Other Regulations. Plans may need to include other reports for deicing/anti-icing chemicals under other environmental regulations, such as SARA Title III, Section 304, 40 CFR Part 355.40 (State Emergency Planning Commission), and any local emergency planning committee for areas likely to be affected by such releases. USEPA requests that releases, even from routine deicing/anti-icing activities, be reported in accordance with applicable regulations.

12.13. NON-STORM WATER DISCHARGES ASSESSMENT AND CERTIFICATION. Non-storm water discharges not authorized by a NPDES permit are illegal. A separate NPDES permit will be required. Such discharges may be a combination of improper or illicit connections, spills, or improper dumping. Precluding unauthorized discharges provides opportunities to dramatically improve the quality of storm water discharges from the airport.

12.13.1. Authorized Non-storm Water Discharges. The general permit allows the following types of non-storm water discharges:

- Discharges from firefighting activities.
- Fire hydrant flushing.
- Potable water sources including waterline flushing.
- Irrigation watering/drainage.
- Lawn watering.
- Uncontaminated ground water and underground drains.
- Discharges from springs and wetlands.
- Routine exterior building washdown that does not use detergents.
- Air conditioning condensate.
- Pavement wash waters where spills or leaks of toxic or hazardous materials have not occurred and where detergents were not used.
- Foundation or footing drains where flows were not contaminated with process materials.

12.13.2. Separate NPDES Permit. Unauthorized dry weather discharges, such as discharges resulting from runway maintenance, aircraft deicing/anti-icing operations, or vehicle and aircraft washes, require a separate NPDES permit based either on application Form 2C, *Wastewater Discharge Information*, for process water, or Form 2E, *Facilities Which Do Not Discharge Process Wastewater*, for non-process water.

12.13.3. Screening Illicit Tenant Connections. Another possible source of unauthorized non-storm water discharges is illicit tenant connections to airport storm water conveyances, which often go unidentified. The implementation of an illicit connection screening program is recommended.

12.13.3.1. Verification Methods. Traditional verification methods to detect non-storm water discharges mixing with final storm water discharges include introduction of fluorometric or other dyes into collection points, back tracing storm sewer discharges during dry weather conditions, physical inspections of storm sewers, measuring pH during dry weather flows, or performing colorimetric testing to detect chlorine, detergents, and metals. A comprehensive evaluation usually calls for several verification methods.

12.13.3.2. Corrective Actions. If an illicit connection is discovered, it should be disconnected or a separate NPDES permit application submitted either Form 2C or Form 2E, to the appropriate permitting authority.

12.13.4. Non-storm Water Connections. Except for firefighting activities, plans should identify non-storm water connections authorized by the permit. For the pollutant components of non-storm water discharges, plans should identify the BMPs and ensure their implementation.

12.13.5. Signed Certification. Plans should include a certification that all storm water discharges from the airport property have been tested or evaluated for the presence of non-storm water discharges. The certification includes the identification of potential significant sources of non-storm water discharges, a description of the methods used and the results of any tests for such discharges, the location of the onsite drainage points that were tested, and the dates of the tests. The signed certification should be in accordance with Part VII.G of the general permit.

12.13.6. Worksheet No. 5. Worksheet No. 5 provides a means to certify required information, such as identification of potential significant sources of non-storm water discharge(s), evaluation date, method of evaluation, and results of testing.

12.13.7. Worksheet No. 6. Worksheet No. 6 provides a Failure to Certify Notification form. If certification of a non-storm water discharge is not feasible because of access to an outfall, manhole, or other access points before the final storm water discharge point(s), then a description should note why the certification was not feasible along with the identification of the potential significant source of non-storm water discharges at the site. Schedules for the airport authority to notify the permitting authority are described in the permit.

12.14. STORM WATER MONITORING AND SAMPLING DATA. If existing storm water sampling data are available, the facility will need to provide a summary of the data and describe the sample collection procedures used. Additionally, scheduled storm water sampling throughout the term of the permit will need to be conducted for certain activities and facilities. Summaries of the data describing pollutants in storm water discharges collected during the term of the permit should be kept with the plan. Data are a means to characterize the quality of storm water discharges in terms of the potential environmental risk by identifying the types and amounts of contaminating pollutants. Once identified,

back tracking should determine the source of problem pollutants. Past data also provides useful information on areas which contributed pollutants to storm water discharges and the problem pollutants.

12.14.1. Sampling Data Tests. Generally, where sampling is required for a facility, the airport authority is required to collect and analyze grab and composite samples in accordance with 40 CFR Part 136. The summary of these data should also describe the sample collection procedures used. Be sure to cross reference the particular storm water outfall sampled to one of the outfalls designated on the airport site map.

12.14.2. Aircraft and Runway Deicing/Anti-icing Activities. Facilities at airports that use more than 100,000 gallons of glycol-based deicing/anti-icing chemicals and/or 100 tons or more of urea on an average annual basis: monitor only those outfalls from the airport facility that collect runoff from areas where deicing/anti-icing activities occur.

12.14.3. Primary Metal Waste Generators. Airport or aircraft maintenance facilities which generate primary metal waste are required to monitor pollutants limited in an effluent guideline to which the facility is subject local, State or Federal.

12.14.4. SARA Title III, Section 313 Facilities. Airport operators and airport tenants required to report under SARA Title III, Section 313 are required semiannually to monitor oil and grease, BOD₅, COD, TSS, Total Kjeldahl Nitrogen (TKN), Total Phosphorus, pH, acute whole effluent toxicity, and any Section 313 water priority chemical for which the facility reports in the baseline general permit. Prudent but adequate monitoring is important since monitoring costs can be the largest annual cost item. Reduction of toxicity can be another major cost for facilities that may need to upgrade existing containment systems to meet permit requirements.

12.15. SITE EVALUATION SUMMARY. Plans should contain a narrative description of the potential pollutant sources and identification of any pollutant source of concern which can be generated by the following airport activities:

- Cargo loading and unloading operations
- Outdoor storage activities
- Outdoor manufacturing or process activities
- Fueling operations
- Vehicle and aircraft maintenance, painting, and lubrication
- Deicing/anti-icing activities
- Significant dust or particulate generating activities
- Onsite waste disposal practices

Assessment should yield specific information on areas, activities, and materials that contribute to contamination of storm water runoff. Depending on the extent of the detail, the information can identify less costly activity-based BMPs to prevent or control pollutants from such activities.

SECTION 3. BEST MANAGEMENT PRACTICES (BMP) IDENTIFICATION (PHASE 3)

12.16. INTRODUCTION. This phase identifies BMPs to address pollutant sources. BMPs are schedules of activities, prohibitions of practices, maintenance procedures, structures, and other practices to prevent or reduce contamination in storm water runoff. Certain BMPs may not apply to a particular geographical region. Applicable tenant BMPs should be referenced in the airport SWPPP.

12.16.1. Activity-Based BMPs. Activity-based BMPs or nonstructural BMPs emphasize *source reduction* through such measures as:

- good housekeeping activities,
- preventative maintenance schedules,
- material management procedures,
- spill prevention and response procedures,
- visual inspections,
- sediment and erosion control,
- management of runoff,
- recordkeeping and reporting,
- employee training, and
- material and product substitution.

Of the listed items, good housekeeping, visual inspections, and employee training may be the most cost-effective and direct means to provide for initial source reduction of contaminants released to storm water runoff. Section 4 provides guidance on employee training programs, implementation, and training schedules.

12.16.2. Structural-Based BMPs. Structural-based BMPs use physical measures to:

- minimize pollution (prevention and containment) or
- divert pollutants for treatment (mitigation and ultimate release).

12.16.3. Effectiveness of BMPs. Success depends on:

- appropriately targeting the cause of the pollution/spill, e.g., lack of employee training, improper (or the lack of) procedures, or poorly maintained equipment.
- understanding site constraints and the storm water quality objectives.
- identification of unique capabilities, limitations, and overall cost of BMP options.
- storm water pollution prevention team interaction including cross-functional, organizational cooperation.

12.16.4. Specific BMPs for Facilities or Activities. Pollutant elimination, prevention, or runoff treatment is best handled by BMPs tailored to a given problem. Examples are aerated detention/retention basins for BOD₅ degradation of glycol. In determining which BMP represents an economically achievable option, the following factors should be considered:

- age of equipment and facilities involved;
- process employed;
- engineering aspects of the application of various types of treatment or control techniques;
- requirements for process changes;
- cost of achieving effluent reduction; and
- non-water quality environmental impact (including energy requirements).

12.16.5. BMP Cost Considerations. During the identification phase, the pollution prevention team should rank targeted activities and facilities on the basis of pollution potential. After prioritizing pollutants, selection of BMPs should consider not only the effectiveness of the alternative, but also the costs for its implementation and maintenance. These two measures provide the team a means to determine which BMPs are most cost-effective. Costly BMPs that resolve only minor pollutants should be avoided. Under certain conditions, minimizing pollutants entering storm water runoff is more cost-effective than treating contaminated storm water runoff, i.e., confronting source reduction as far upstream as possible can maximize the economics downstream. Source reduction for given pollutants may be implemented immediately through activity-based BMPs instead of structural-based BMPs that require more planning, a lengthier period for implementation, or have particular drawbacks, such as physical space requirements.

12.17. GOOD HOUSEKEEPING. Good housekeeping practices are inexpensive, activity-based BMPs which can be performed easily by employees or tenants. Plans should describe how implemented practices reduce the contribution of pollutants to storm water. Examples of good housekeeping practices that should be implemented regularly are as follows:

12.17.1. Routine Clean-up Operations.

12.17.1.1. Daily Activities.

12.17.1.1.1. Airport Facilities. Maintaining working and storage areas in a clean and orderly manner are inexpensive, activity-based BMPs which can be implemented immediately. Besides scheduled sweepings, removing loose and trapped materials in and around drainage inlets or other similar structures should be part of the daily routine.

12.17.1.1.2. Aircraft Servicing. Spills of lavatory waste, oils, and hydraulic fluids should be attended to so they will not contribute pollutants to storm water. Paragraph 12.20 provides guidance for fueling/defueling spills.

12.17.1.1.3. Cleaning Small Spills. A product's MSDS is a good source of recommended actions for spills and container leaks. Common BMPs for cleaning small spills or releases are sweeping, vacuuming, or using sorbent pads and gels. Additionally, MSDSs provide emergency phone numbers (manufacturer and an 800 hotline) and occupational health hazard information.

12.17.1.2. Seasonal Activities.

12.17.1.2.1. Snowbanks. Snowbanks during the thawing season can cause not only environmental pollution but safety concerns. Debris, trash, and other foreign objects imbedded in snowbanks should be recovered and disposed of properly. To reduce deicing/anti-icing chemicals (BOD₅ impacts) in receiving bodies of water, snow banks should be at a distance from inlet drains and other airport discharge points. AC 150/5200-30, *Airport Winter Safety and Operations*, provides guidance on height and location of snowbanks near runways during clearing operations.

12.17.1.2.2. Turf Management. Refraining from over-application of fertilizers is one way to lessen chemical excess mixing with storm water runoff. The airport authority should emphasize to employees the need for a good turf cover to prevent soil erosion and sedimentation. Sediments have the ability to bind with other contaminants which can then be transported downstream. Allowing grass clippings to remain on the ground as a form of soil nutrient is another activity-based BMP that contributes to good turf and lower fertilizer costs.

12.17.1.2.3. Agricultural Aerial Spraying. Even though airport authorities may not operate agricultural spraying equipment, they have a responsibility for preventing pesticide contamination of storm water. Targeting specific BMPs to the use of agricultural chemicals can be effective. For example, cleaning of equipment and pesticide containers at the end of the day or when different chemicals are sprayed should be followed by proper disposal of wastewater.

12.17.2. Trash, Litter, and Recyclable Management Program. An immediate and inexpensive BMP to reduce the amount of trash or hazardous waste that could enter the storm water drainage system is having appropriate trash receptacles available. Acceptable practices should be observed when recycling or disposing of used oil and batteries (vehicle and aircraft). Containers should be of adequate size, routinely emptied, and checked for leaks. Additional improvements can be achieved by placing trash containers away from drainage inlets and covering those containers exposed to the elements.

12.17.3. Material Inventory Management Program. The activity-based BMP of rotating stock, old to front, should encourage employees to use older products first. Effective shelf life programs help to reduce over-purchasing of materials with the monetary benefits of lower storage and handling costs and, for products whose shelf life has expired, replacement and disposal costs. Disposal cost of unused portions may be further lowered by purchasing products in containers which closely match the quantities

used. Locating product storage areas in facilities away from drainage areas is a BMP that affords extra cleanup time of spills before they enter floor drains.

12.18. PREVENTIVE MAINTENANCE PRACTICES. Plans should include scheduled practices for preventive maintenance of facilities, equipment, and storm water structures and devices.

12.18.1. Runway Maintenance. Surface texture maintenance and runway grooving are activities with pollution potential. AC 150/5320-12, *Measurement, Construction, and Maintenance of Skid Resistant Airport Pavement Surfaces*, provides BMPs for both activities.

12.18.2. Facility Equipment. Facility equipment should receive scheduled inspections and preventive maintenance. Table 12-2 provides items whose malfunction can cause spills, leaks, or other situations leading to contamination of storm water runoff. Such items provide a starting point for preventive maintenance programs.

12.18.3. Storm Water Structures and Devices. Storm water structures and devices should receive timely inspections, such as cleaning out collected debris from oil/water separators after a heavy storm event. Plans should include routine inspection of traditional storm water management practices used to divert, infiltrate, reuse, and otherwise manage storm water runoff to reduce pollutants discharged from airport property.

12.18.4. SARA Title III, Section 313 Facilities. Permits impose additional inspection requirements for preventive maintenance of tenant facilities subject to SARA Title III, Section 313 for water priority chemicals (general permit Part IV.D.7.b.(7)). Inspections are usually based on facility design and operational experience. Corrective action should be taken immediately or the facility unit or process should be shut down until the problem is repaired. All areas of the regulated facility should be inspected for the following at the intervals specified in the plan:

- Leaks or conditions which would lead to discharges of Section 313 water priority chemicals.
- Conditions which could lead to direct contact of storm water with raw materials, intermediate materials, waste materials, or products.
- Leaks, wind blowing, corrosion, support or foundation failure, or other deterioration or non-containment of piping, pumps, storage tanks and bins, pressure vessels, process and material handling equipment, and material bulk storage areas.

12.19. SPILL PREVENTION AND RESPONSE PROCEDURES FOR AIRPORT FACILITIES. SWPPPs should include spill prevention and response procedures for airport owned facilities (and special procedures for particular tenant facilities as warranted) including regular visual inspections, adopting good housekeeping practices, and reducing and reusing process materials to minimize waste generation on site.

12.19.1. Airport Owned Facilities. Spill prevention programs should include practices for handling and storing products. Response procedures should include how to use spill control materials and equipment, contain spills, isolate spills from storm sewer collection points (minimization), reporting requirements, and disposal of collected material.

12.19.2. Recordkeeping and Internal Reporting Procedures. The plan should identify an employee responsible for maintaining records of spills, actions taken, and reporting required. The individual should be available at reasonable times of facility operation. Contingency plans should provide adequate management of this section of the airport SWPPP in case of unanticipated absences.

12.19.3. SARA Title III, Section 313 Facilities. USEPA baseline requirements of the general permit set forth more specific requirements for facilities subject to reporting requirements for water priority chemicals (Part IV.D.7.b.(7)). Consequently, plans should describe when a leak or spill of a Section 313 water priority chemical has occurred and how contaminated soil, materials, or debris are removed promptly and disposed of in accordance with Federal, state, and local requirements. These facilities also require a designated person responsible for spill prevention, response, and reporting procedures.

Table 12 - 2. Equipment to inspect

Pipes/Pumps Storage tanks and bins Pressure vessels Pressure release valves Process and material handling equipment Storm water management devices (oil/water separators, catch basins, etc.)

12.20. SPILL PREVENTION AND RESPONSE PROCEDURES FOR AIRCRAFT FUELING/DEFUELING ACTIVITIES. Aircraft fueling (and defueling) operations have the potential to be major sources of storm water pollution. The BOD₅ for aviation kerosene breakdown is considerably higher than that required for deicing/anti-icing fluids. Jet A, A-1, and B are kerosene type distillates compared to aviation gasoline (AVGAS) 80, 100, and 100LL. Effects of fuel and oil are not as immediate or apparent as kerosene in storm water although they can be as serious and costly in terms of remediation.

12.20.1. Fire Safety and Spillage. The fire safety procedures currently practiced by airport authorities may be referenced by the plan to cover fuel spills. Procedures should cover the three main areas of aviation fuel spills: fuel farms, transfer pipelines/pumps, and aircraft fueling/defueling areas. Since fuel spills and releases occur mostly during fueling of aircraft by fuelers, dispensing activities should receive particular attention. The airport SWPPP should also describe measures to prevent or minimize the discharges of fuel to storm water runoff, as well as measures to minimize release of contaminated storm water when a discharge does occur.

12.20.2. Spill Clean Up. AC 150/5230-4, *Aircraft Fuel Storage, Handling, and Dispensing On Airports*, provides cleanup practices within the framework of fire safety.

12.20.2.1. Small Spills. Collecting spills can be accomplished using some form of absorbent material, emulsion compounds, rags, or “pigs”. Absorbent materials include sand, sawdust, or specialty textiles. The latter item being more effective, absorbing over 10 to 20 times their own weight.

12.20.2.2. Large Spills. Large fuel spills should be blanketed first with foam then dispersed using the washdown techniques within AC 150/5230-4 considerations. Although a fuel dispersant, usually a detergent (surfactant), used to emulsify the fuel and dissolve it in water, may aid cleanup, *avoid* washing the dispersant into drains because of fire hazard and added BOD₅ loads. Also, detergents have been known to strip out trapped oil segregated by used-oil separators and interfere with equipment and pipes at

POTWs. Such potential problems may negate the usefulness of a fuel dispersant. Spilled fuel can be removed using mobile vacuum cleaners (attached to or built into trucks) which siphon fuel spills as well as deicing/anti-icing waste.

12.20.3. Aircraft Fueling/Defueling. Fixed base operator (FBO) fueling plans must describe how fuel is dispensed from mobile fuelers or hydrant fuelers (pit/cabinet) boxes. Hydrants with cathodic protection will reduce corrosion and subsequent leaks. Another source of fueling spills may result from faulty aircraft fuel connections.

12.20.3.1. Large Airports. Airports having fuel pits/cabinets can reference 14 CFR Part 139.321 inspection activities in their plans. Scheduled activities may include inspection of gaskets, valves, couplers, etc., and removal of standing fuel.

12.20.3.2. General Aviation Airports. For mobile fueling operations at general aviation airports, an effective BMP is designating specific fueling areas where proper surface drainage and collection reservoirs exist.

12.20.4. Fuel Delivery and Storage. Self-inspection programs (14 CFR Part 139.327) which cover fuel farm inspections can be referenced in the plan. For inspection of tenant fueling facilities, plans can reference current procedures (14 CFR Part 139.321). AC 150/5230-4 provides some BMP related information on good housekeeping practices, delivering aviation fuel to storage areas, and the dispensing of fuel.

12.21. SPILL PREVENTION AND RESPONSE PROCEDURES FOR GROUND VEHICLE FUELING. To minimize fuel spill contamination, simple BMPs are refraining from topping off vehicle fuel tanks and having sorbent materials available in the fueling area for when small spills occur. Employees should make cleanup a part of their routine. Fueling stations with impervious pavement allow easier cleanup or retention of spills. High volume fueling stations may require installation of diversion drains and/or curbing to minimize storm water contamination by spilled fuel. Section 3.1 of USEPA document 832-R-92-006 provides specific BMPs for ground vehicle fueling stations.

12.22. SPILL PREVENTION AND RESPONSE PROCEDURES FOR DEICING/ANTI-ICING ACTIVITIES. Plans should include practices for dealing with aircraft and pavement deicing/anti-icing runoff and procedures for the handling and storage of such products. Airport authorities performing pavement deicing/anti-icing activities should evaluate their procedures for effectiveness. Airport authorities should require tenants engaged in ground deicing/anti-icing to keep accurate records of glycol usage to aid in reporting requirements.

The following steps will help reduce the storm water impacts of leaks and spills:

12.22.1. Education.

- Be aware that different materials pollute in different amounts. Make sure that each employee knows what a “significant spill” is for each material they use, and what is the appropriate response for “significant” and “insignificant” spills.
- Educate employees and subcontractors on potential dangers to humans and the environment from spills and leaks.
- Hold regular meetings to discuss and reinforce appropriate disposal procedures (incorporate into regular safety meetings).

- Establish a continuing education program to indoctrinate new employees.
- Have contractor's superintendent or representative oversee and enforce proper spill prevention and control measures.

12.22.2. General Measures. Keep in mind that notification of government agencies may be required.

- To the extent that the work can be accomplished safely, spills of oil, petroleum products, substances listed under 40 CFR parts 110,117, and 302, and sanitary and septic wastes should be contained and cleaned up immediately.
- Store hazardous materials and wastes in covered containers and protect from vandalism.
- Place a stockpile of spill cleanup materials where it will be readily accessible.
- Train employees in spill prevention and cleanup.
- Designate responsible individuals to oversee and enforce control measures.
- Spills should be covered and protected from storm water run-on during rainfall to the extent that it doesn't compromise clean up activities.
- Do not bury or wash spills with water.
- Store and dispose of used clean up materials, contaminated materials, and recovered spill material that is no longer suitable for the intended purpose in conformance with the provisions in applicable BMPs.
- Do not allow water used for cleaning and decontamination to enter storm drains or watercourses. Collect and dispose of contaminated water in accordance with WM-10, Liquid Waste Management.
- Contain water overflow or minor water spillage and do not allow it to discharge into drainage facilities or watercourses.
- Place proper storage, cleanup, and spill reporting instructions for hazardous materials stored or used on the project site in an open, conspicuous, and accessible location.
- Keep waste storage areas clean, well organized, and equipped with ample cleanup supplies as appropriate for the materials being stored. Perimeter controls, containment structures, covers, and liners should be repaired or replaced as needed to maintain proper function.

12.22.3. Cleanup.

- Clean up leaks and spills immediately.
- Use a rag for small spills on paved surfaces, a damp mop for general cleanup, and absorbent material for larger spills. If the spilled material is hazardous, then the used cleanup materials are also hazardous and must be sent to either a certified laundry (rags) or disposed of as hazardous waste.

- Never hose down or bury dry material spills. Clean up as much of the material as possible and dispose of properly. See the waste management BMPs in this section for specific information.

12.22.4. Minor Spills.

- Minor spills typically involve small quantities of oil, gasoline, paint, etc. which can be controlled by the first responder at the discovery of the spill.
- Use absorbent materials on small spills rather than hosing down or burying the spill.
- Absorbent materials should be promptly removed and disposed of properly.
- Follow the practice below for a minor spill:
 - Contain the spread of the spill.
 - Recover spilled materials.
 - Clean the contaminated area and properly dispose of contaminated materials.

12.22.5. Semi-Significant Spills.

- Semi-significant spills still can be controlled by the first responder along with the aid of other personnel such as laborers and the foreman, etc. This response may require the cessation of all other activities.
- Spills should be cleaned up immediately:
 - Contain spread of the spill.
 - Notify the project foreman immediately.
 - If the spill occurs on paved or impermeable surfaces, clean up using "dry" methods (absorbent materials, cat litter and/or rags). Contain the spill by encircling with absorbent materials and do not let the spill spread widely.
 - If the spill occurs in dirt areas, immediately contain the spill by constructing an earthen dike. Dig up and properly dispose of contaminated soil.
 - If the spill occurs during rain, cover spill with tarps or other material to prevent contaminating runoff.

12.22.6. Significant/Hazardous Spills.

- For significant or hazardous spills that cannot be controlled by personnel in the immediate vicinity, the following steps should be taken:
 - Notify the local emergency response by dialing 911. In addition to 911, the contractor will notify the proper county officials. It is the contractor's responsibility to have all emergency phone numbers at the construction site.

- Notify the state Emergency Services Warning Center.
- For spills of federal reportable quantities, in conformance with the requirements in 40 CFR parts 110,119, and 302, the contractor should notify the National Response Center at (800) 424-8802.
- Notification should first be made by telephone and followed up with a written report.
- The services of a spills contractor or a HAZMAT team should be obtained immediately. Construction personnel should not attempt to clean up until the appropriate and qualified staffs have arrived at the job site.
- Other agencies which may need to be consulted include, but are not limited to, the Fire Department, the Public Works Department, the Coast Guard, the Highway Patrol, the City/County Police Department, and the Department of Toxic Substances.

12.22.7. Reporting.

- Report significant spills to local agencies, such as the Fire Department; they can assist in cleanup.
- Federal regulations require that any significant oil spill into a water body or onto an adjoining shoreline be reported to the National Response Center (NRC) at 800-424-8802 (24 hours).

12.23. MATERIAL SUBSTITUTION. Environmentally friendlier products should be used whenever practical. For example, phosphate-free detergents for washing vehicles can be substitutes for solvents in cleaning up oil-based spills. Natural products for absorbing fuel spills and different chemically-based runway deicer/anti-icers (AC 150/5200-30) are also available.

12.24. AIRCRAFT, GROUND VEHICLE, AND EQUIPMENT WASH WATER. USEPA considers wash water as a process wastewater discharge which requires disposal to sanitary sewers or some degree of pretreatment prior to release. Oil, grease, metals, and emulsified wastes are common ingredients found in aircraft and vehicle wash water waste.

12.24.1. SWPPP Requirements. Airport SWPPPs should describe measures which prevent or minimize the contamination of the storm water runoff from all areas used to clean aircraft, ground vehicles, and other equipment. Cleaning areas should be delineated on the facility site map.

12.24.2. BMPs. One activity-based BMP is designating washing areas which direct wash water waste to sanitary sewers or collect it for pretreatment. Substituting phosphate-free detergents can simplify pretreatment. When large quantities of wash water are discharged, it may be necessary to use specific pretreatments.

12.24.2.1. Aircraft Washes. Chapter 11 discusses collection and treatment of large quantities of wash water from aircraft wash racks by an air flotation system. This is one option for activities that contribute large quantities of oil, grease, and emulsified wastes.

12.24.2.2. Ground Vehicle and Equipment Washes. USEPA provides activity-specific BMPs for vehicle and equipment wash waters in section 3.4 of USEPA 832-R-92-006.

12.25. AIRCRAFT, GROUND VEHICLE, AND EQUIPMENT MAINTENANCE AREAS. SWPPPs should describe measures which prevent or minimize the contamination of the storm water

runoff from all areas used to store aircraft, ground vehicles, and equipment awaiting maintenance. Designated maintenance areas should be delineated on the facility site map.

12.25.1. Aircraft Maintenance. The operations conducted at aircraft maintenance shops include cleaning, reconditioning, and overhauling. Other operations include painting/paint removal activities. The principal wastes are metal cleaning, treating, and plating solutions. Plating room waste consists of acids, cyanide, and heavy metals such as zinc, copper, lead, and chromium. Engine repairs and test cells generate alkaline cleaner waste, oil, grease, and emulsified materials. Chapter 10 provides some specific BMP pretreatments for plating waste reduction, chromic acid recovery, chromium reduction, phenolic waste treatments, and cyanide wastes treatments.

12.25.2. Ground Vehicle and Equipment. USEPA provides activity-specific BMPs for vehicle and equipment maintenance wastes in section 3.2 of USEPA 832-R-92-006.

12.26. LOADING/UNLOADING DOCKS AND STORAGE AREAS. Plans should describe measures which prevent or minimize the contamination of the storm water runoff from loading/unloading receiving docks and material storage areas. Bulk fuel storage activities should also be identified. These areas should be delineated on the facility site map. Because of the nature of these operations, both activity and structural BMPs may be necessary.

As a first step, identify all equipment at your site that may be exposed to storm water, or that may discharge potential pollutants that may be exposed to storm water. Identify the kinds of pollutants each piece of equipment may generate-lubricants, coolants, and other possible sources of leaks or discharges. Be creative and thorough in developing the list. The inventory should include rooftop cooling towers or air conditioners; rooftop air vents for industrial equipment; outdoor air compressors and other service equipment; indoor wet processes where leaks or discharges may discharge to outdoor areas; and material transfer areas, such as loading areas where forklifts or trucks may carry pollutants outdoors on their tires.

Using the equipment inventory, assign an employee to inspect each piece of equipment on a regular basis to see that it is functioning properly. This could be the employee responsible for operating the equipment if it is used regularly, or may be a maintenance staff member for equipment on the roof or in seldom-seen places. Inspect for leaks, malfunctions, and staining on and around the equipment, and other evidence of leaks and discharges. Assign the inspecting person to be responsible for reporting a spill. Develop a routine for taking actions on the report: cleaning up the spill, and repairing the leak to prevent future spills.

Where possible, take the next step toward full pollution prevention and make modifications to prevent storm water from contacting the equipment or its discharges. Place equipment on an impermeable surface, or install a drip pan beneath potential leak points. To minimize the amount of rainwater that contacts the equipment, a simple roof may be constructed and a berm installed to prevent run-on and runoff. If the equipment requires a "wet" process (that is, operations that inevitably release wash water or process liquids), place the equipment on a paved surface and install a connection to the sanitary sewer.

Storm water in secondary containment areas often accumulates from direct rainfall into open containments. Water that has contacted storage vessels, or the pumping and transfer equipment associated with storage and handling, is considered to have contacted industrial activities and may not be discharged to the storm drains. The containment may be roofed to avoid the discharge problem. If this is not possible, or you wish to avoid the cost, you need to identify an acceptable disposal for water from the containment. One common solution is a portable pumping system that can be moved to accommodate separate containment structures on your site. The equipment can pump water into a truck for a portable

temporary holding tank. The water then can be tested and disposed of according to whether any pollutants are present. Some disposal options are:

- If it meets criteria to be defined as hazardous waste, employ a certified hazardous waste hauler for disposal at a permitted hazardous waste facility.
- If it contains constituents similar to process wastewater for which your onsite wastewater pretreatment facilities are designed, pre-treat the water and discharge to the sanitary sewer.
- If it meets standards for your industrial discharge permit, discharge it to the sanitary sewer without pretreatment (if your wastewater authority permits).
- Reuse it on your site in an appropriate manner: industrial process water, equipment wash water, steam cleaning makeup, or another use where the water will eventually be discharged as industrial or sanitary wastewater. It may be necessary to invest in a truck or plumbing to convey the water to its reuse location.

12.26.1. Activity-Based BMPs. Activity-specific BMPs should be implemented to improve the processing of deliverables at loading/unloading receiving docks and their subsequent storage at the site. A daily cleanup, sweeping to remove trash, etc., and/or responding to spills lessens the amount of material exposed to storm water runoff by wind or precipitation. Containing spills is one of the primary methods of minimizing exposure of contaminants to storm water runoff. Employees should have cleanup materials, such as sorbents or gelling agents, available for cleanup. Section 4.3 of USEPA document 832-R-92-006 discusses the advantages, disadvantages, and what to consider before implementing sweeping, sorbents, and gelling agents.

12.26.2. Structural-Based BMPs. Structural BMPs to minimize or separate storm water originating at receiving docks include drip pans, catch basins, sump pumps, containment diking, and curbing. Section 4.2 of USEPA document 832-R-92-006 discusses the advantages, disadvantages, and what to consider before implementing these alternatives.

12.27. SOIL EROSION AND SEDIMENTATION CONTROLS. Severe weather, airfield operations, and construction activities can accelerate soil erosion and subsequent sedimentation. Sedimentation occurs when loose soil particles are suspended in surface runoff or wind and are deposited in streams and other bodies of water.

12.27.1. Control Measures. Plans should identify areas which have potential for significant soil erosion and the soil stabilization or structural measures implemented to limit such problems. The optimum BMPs for sediment and erosion prevention depend upon site conditions, such as topography, soil type, climate, and the nature of airport activities, such as degree of construction and type of airfield operation. All BMPs, prior to implementation, should be reviewed for (1) consistency with AC 150/5300-13, *Airport Design*, such as, runway safety area standards, and (2) wildlife mitigation measures.

12.27.2. Construction Activities. Construction activities have the potential for severe damage to water quality because of high sediment loads. Besides soil erosion, changes to drainage patterns, and loss of vegetation, construction can contribute pollutants, such as lubricants, bitumens, phosphorous, nitrogen, and solid wastes. Staged construction activities may need to schedule specific BMPs, such as controlling wash water or waste flows during concrete mixing or curing operations.

12.27.2.1. Less than Five Acres. Construction activities on sites of less than five acres can be addressed by the airport SWPPP developed for industrial activities which differs from SWPPPs developed for

construction activities. BMP guidance is available from AC 150/5370-10, AC 150/5320-5, *Airport Drainage*, and Chapter 3 of USEPA publication USEPA 832-R-92-005.

12.27.2.2. Five Acres or More. Construction activities on sites of five acres or more should be addressed by a separate SWPPP for construction activities. For this case, USEPA document USEPA 832-R-92-005, *Storm Water Management for Construction Activities: Developing Pollution Prevention Plans and Best Management Practices*, provides guidance on how to develop construction activity plans.

12.27.3. Airfield Activities. Plans may need to address certain airfield activities that contribute to soil erosion and sediment loads in receiving bodies of water. Potential activities include the following:

12.27.3.1. Emergency Response Drills. Readiness drills to evaluate Airport Emergency Plans (14 CFR Part 139.325) conducted off paved areas may cause localized turf damage requiring post-exercise remediation.

12.27.3.2. Removal of Disabled Aircraft.

12.27.4. Jet Blast. AC 150/5300-13 provides shoulder stabilization practices and blast pad design recommendations to reduce soil erosion. See paragraph 12.17.3 for related guidance on turf management.

12.27.5. Preventive Practices. Structural BMPs for erosion protection include vegetation, flow dispersion, swales, slope reduction, dikes/berms, sedimentation traps, diversion structures, curbing, rip rap, and culverts.

USEPA provides numerous sediment and erosion prevention and control measures in Chapter 4 of their publication USEPA 832-R-92-006.

SECTION 4. PLAN IMPLEMENTATION (PHASE 4)

12.28. INTRODUCTION. Permits require schedules to implement selected BMPs. As previously noted, this is one of the responsibilities of team members. Their knowledge of the day-to-day operations of regulated facilities and activities and how they interrelate with the selected BMPs will normally yield realistic and achievable schedules. Table 12-5 provides implementation deadlines for the general permit. Worksheet No. 8 provides a means to list implementation schedules.

12.29. EMPLOYEE TRAINING PROGRAMS. SWPPPs should include employee training programs which address pollution prevention. This will inform employees at all levels of responsibility (including tenants) of the components and goals described in the airport SWPPP. The frequency should take into account the complexity of the management practices, staff turnover, and employee workloads (multiple duties). Worksheet No. 9 provides a means to organize employee training topics and schedules.

12.29.1. Employee Training Programs.

12.29.1.1. SWPPP Components and Goals. Each plan component and goal should address the "how" and "why" tasks that are to be implemented. This conveys to the employees understanding of potential pollutant problems and how their involvement directly affects the effectiveness of the plan.

12.29.1.2. Training Topics. At a minimum, training should address the major topics contained in the plan, such as spill prevention and response, good housekeeping, and material management practices. Given the chemical characteristics for certain spilled chemicals, training should address relevant OSHA

training requirements for employees responding to spills. Teaching strategies may focus on how employees can prevent spills, respond safely and effectively to an accidental spill, and recognize potential situations which could lead to storm water contamination. Specialized training programs may also be implemented to cover specific topics, such as runway deicing/anti-icing applications and follow-up cleanup procedures.

12.29.2. Special SARA Title III, Section 313 Training Programs. For airport or tenant facilities reporting under section 313, the baseline general permit specifies training requirements for employees and contractor personnel that work in areas where SARA Title III, Section 313 water priority chemicals are used or stored (see general permit Part IV.D.7.b.(9)). Criteria for regulated chemical categories can be found in 40 CFR Part 116.440, Appendix D of Part 122, and Part 372.65. These employees should be trained at least once per year in the following areas:

- Preventative measures, including spill prevention and response and preventive maintenance,
- Pollution control laws and regulations,
- Goals and objectives of the facility's plan, and
- Features and operations of the facility which are designed to minimize discharges of Section 313 water priority chemicals, particularly spill prevention procedures.

SECTION 5. EVALUATION (PHASE 5)

12.30. INTRODUCTION. Permits require the evaluation of the effectiveness of the BMPs implemented to prevent or control identified pollutant sources. Inspection records provide the airport authority (the permittee) the documentation that management procedures are in place and, when necessary, what corrective actions were taken. The extent of evaluation will depend on the permit and the contents of the plan. At a minimum, airport authorities should conduct site evaluations and retain records of all inspections and reports. Scheduled evaluations may warrant revisions of plans to provide more effective BMPs or addition and/or deletion of BMPs for new and/or discontinued activities which can generate pollutants.

12.30.1. Monitoring Timetables. Monitoring permitted facilities and activities for compliance varies according to the negotiated permit.

12.30.2. Compliance Evaluation. Plans should identify qualified employees responsible for conducting site compliance evaluations at the scheduled intervals. These employees, as frequently as specified in the permit but at least annually, must perform the following:

- Visually inspect storm water drainage areas, particularly those regulated areas associated with industrial activity, for evidence of pollutants entering the drainage system;
- Look for changes in physical site conditions, onsite activities, and material handling and storage practices;
- Evaluate the effectiveness of implemented BMP measures to reduce pollutant loadings and whether additional control measures are needed;

- Observe structural storm water management measures, sediment and erosion control measures, and other structural pollution prevention measures to ensure proper operation (e.g., determine maintenance of structural measures); and
- Inspect any equipment needed to implement the plan, such as spill response equipment.

12.30.3. Deadlines for Revising SWPPPs. Based on the results of the compliance inspection, the plan should be revised as appropriate within two weeks of the inspection and should provide implementation of any necessary changes to the plan (measures and controls) in a timely manner, but at least within 12 weeks of the inspection.

12.30.4. Compliance Inspection Report. Plans should retain compliance inspection reports for at least one year after the permit expires. The report should include inspection results and follow up actions, the date of inspection and the qualified employee who conducted the inspection, and any incidents of noncompliance or a signed certification that the facility is in compliance with the plan and the permit. All incidents of noncompliance should be documented in the compliance inspection report. Where there are no incidents of noncompliance, the inspection report should contain a certification that the facility is in compliance with the plan. The signed report should be in accordance with the general permit, Part VII.G, and kept with the SWPPP.

12.30.5. Scope of Site Compliance Evaluation. The scope of the site compliance evaluation depends on various factors, including the scope of the plan and the size of the airport. As each airport's SWPPP is unique, the exact inspection format will vary. One approach follows:

- Review the plan and draw up a list of those areas which are included in the storm water discharge permit;
- List all equipment, containment, and storm water pollution prevention measures (BMPs) in these areas covered in the plan;
- Review facility operations (activities) for the past year to determine if any new areas should be included in the original SWPPP, or if any areas were modified so as to require plan modifications; change the plan as necessary;
- Conduct inspections to determine if all storm water pollution prevention measures (BMPs) are accurately identified in the plan and that they are in place and working properly;
- Document findings; and
- Modify the airport SWPPP as necessary.

12.30.6. Availability of Documentation. All documentation regarding conditions necessitating modification to the plan should be kept on file as part of the airport SWPPP for one year after the permit expires.

12.31. VISUAL INSPECTIONS. Regular visual inspections should be performed in addition to or as part of the comprehensive site evaluation required under Part IV.4 of the general permit. These are not comprehensive evaluations of the SWPPP program. Rather, they are a routine examination of facilities and activities to identify potentially contaminating conditions. Conducting inspections after significant storm events can identify necessary changes of a BMP more quickly to assure adherence to the negotiated

SWPPP. Results of all inspections should be tracked to implement more effective actions when necessary, and records should be maintained.

12.31.1. Visual Inspection Plan. Avoid complicated and labor intensive procedures. Determine what areas of the facility could potentially contribute pollutants to storm water runoff and devise and implement a visual inspection program based on this information. To a large degree, the usefulness of any visual inspection plan rests with the inspecting employees.

12.31.2. Qualified Employee. Inspections should be performed by qualified employees who will inspect equipment and areas of concern at scheduled intervals. Qualified employees are properly trained, familiar with the objectives of the airport SWPPP program, and use proper record keeping and reporting procedures. The frequency of inspections will depend on the types and amounts of materials handled at a facility, implemented BMPs, and other relevant factors. For example, older equipment as compared to newer equipment should be inspected at more frequent intervals. Tables 12-3 and 12-4 are provided as starting points.

12.32. RECORDKEEPING AND INTERNAL REPORTING. Permits require keeping updated, accurate records and related documents with the airport SWPPP. Besides including inspection and maintenance activity records, incident reports (such as spills or other discharges) along with other pertinent information describing the quality and quantity of storm water discharges should also be included with the plan. Records should note date of inspection, who conducted the inspection, areas inspected, type of problems found, corrective steps, and who was notified (including Federal, state, or local authorities).

12.32.1. Recording Items. Records should include, if practicable, the following actions:

12.32.1.1. The date and time of the incident, weather conditions, duration, cause, environmental problems, response procedures, parties notified, recommended revisions to the BMP program, operating procedures, and/or equipment needed to prevent recurrence.

12.32.1.2. The airport authority may report all the airport deicing and anti-icing operations that occurred in a 24-hour period as an aggregate release. This report should include the date, type of deicing chemical, estimated quantity released, and a description of the conditions causing the release. Worksheet No. 10 provides an example format. Information probably will be needed for quantities used by airlines and other tenants.

Table 12 - 3. Areas to inspect

Areas around equipment listed in Preventive Maintenance box
Areas where spills and leaks have occurred in the past
Material storage areas (tank farms, drum storage)
Outdoor material processing areas
Material handling areas (e.g., loading, unloading, transfer areas)
Waste generation, storage, treatment and disposal areas

Table 12 - 4. Visual Inspection Checklist

Do you see:
Corroded drums or drums without plugs or covers?
Corroded or damaged tanks, tank supports, or tank drain valves?
Torn bags or bags exposed to rain water?
Corroded or leaking pipes?
Leaking or improperly closed valves and valve fittings?
Leaking pumps and/or hose connections?
Broken or cracked dikes, walls, or other physical barriers designed to prevent storm water from reaching stored materials?
Windblown dry chemicals?
Improperly maintained dry chemical conveying systems?

12.32.1.3. Formal written reports are helpful in reviewing and evaluating the discharges and making revisions for more effective BMPs. Document all calls and reports to the National Response Center in the event of a reportable quantity discharge. 40 CFR Part 117 and 40 CFR Part 302 provide more information on reporting spills or other discharges.

12.32.1.4. A list of the procedures for notifying the appropriate airport employee, as well as the names and telephone numbers of responsible employees, enables more rapid reporting of releases and responding to spills and other incidents.

12.32.2. Duration of Records. Records of spills, leaks, or other discharges, inspections, and maintenance activities should be retained for at least one year after the permit expires.

12.33. REVISION OF SWPPPS. Airport authorities should expect to revise plans to reflect changes, such as new airport construction, modified activities, or maintenance procedures. Other revisions may result from eliminating BMPs which prove ineffective in preventing or controlling the discharge of pollutants.

12.33.1. Team Member Responsibilities. When changes are necessary, the pollution prevention team should discuss alternative BMPs, perform cost/benefit analysis of the alternative BMPs, develop implementation schedules, and modify the airport SWPPP accordingly.

12.33.2. Modified Notifications. Airport authorities are not required to submit a notice to the Director (permitting authority) each time the airport SWPPP is modified if the airport (or tenant) initiates the modification process. In contrast, if the Director notifies the airport authority (or tenant) that certain changes are required, then notification of the modification is required.

SECTION 6. SPECIAL SWPPP REQUIREMENTS

12.34. INTRODUCTION. Authorities of airports that: 1) discharge storm water through large or medium municipal separate storm sewer systems; 2) have facilities on airport property subject to SARA Title III, Section 313 reporting requirements; or 3) stockpile salt for non-aeronautic uses that has the

potential to contaminate storm water runoff entering a body of water, will need to include up to three additional special requirements beyond the baseline BMPs cited in sections 1, 2, and 3.

12.35. SPECIAL REQUIREMENTS FOR DISCHARGES THROUGH LARGE AND MEDIUM MUNICIPAL SEPARATE STORM SEWER SYSTEMS. The November 16, 1990, storm water discharge permit regulations require large and medium municipal separate storm sewer systems serving a population of 100,000 or more to develop storm water management programs in order to control pollutants discharged through their municipal systems. Airports covered by general permits will typically be required to submit a copy of their Notice of Intent (NOI) to the municipal operator.

12.35.1. Responsibility of the Airport Authority. USEPA emphasizes that it is the responsibility of the airport authority to inform the municipal authority of all storm water discharges associated with industrial activity to the separate storm sewer system. This includes non-storm water discharge activities, such as wash water from aircraft, vehicles, or equipment, and dry weather chemical discharges from aircraft deicing/anti-icing operations and runway maintenance. The airport authority should comply with:

- conditions in municipal storm water management programs developed under the NPDES permit issued to the storm sewer system into which the airport discharges, provided that the airport authority was directly notified of the requirements by the municipal operator.
- deadlines specified in the airport SWPPP as listed in table 12-5.

12.35.2. Additional Special Requirements. In some situations, the municipal operator may find it necessary to impose additional special requirements on the airport's SWPPP or a tenant's SWPPP because of the class of industrial facilities or a particular industrial activity. For example, runoff from aircraft deicing/anti-icing activities may require pretreatment. AC 150/5300-14 lists probable pretreatment parameters. One way the municipal operator can ensure the airport authority (or a tenant) complies with the special requirements is to include a provision in the NPDES storm water discharge permit that directly requires compliance. This mechanism provides a basis for enforcement action to be directed, when necessary, against the airport authority or tenant of the facility with a storm water discharge associated with an identified industrial activity.

Table 12 - 5. USEPA general permit requirements

Schedule for Plan Development and Implementation Part IV.A.		
Facility Startup Date	Deadline for Plan Completion	Deadline for Plan Implementation
Industrial activity on or after January 1, 1993	48 hours prior to commencement of discharge (upon submittal of NOI)	48 hours prior to commencement of discharge (upon submittal of NOI)

12.36. SPECIAL REQUIREMENTS FOR SARA TITLE III, SECTION 313 REPORTING FACILITIES. Section 313 of SARA requires operators of facilities that handle toxic chemicals in amounts exceeding threshold levels (in accordance with 40 CFR Part 372.25) to report to the Federal Government on an annual basis. Because these types of facilities can handle certain amounts of toxic chemicals, USEPA concluded that they have an increased potential to degrade the water quality of receiving bodies of water.

12.36.1. Contributing Activities. Examples of contributing activities include cleaning, reconditioning, plating, and overhauling at aircraft maintenance facilities. Plating wastes, which are mainly inorganic, consist of acids, cyanide, and heavy metals such as zinc, copper, lead, and chromium. Reportable cyanide, chromium, and other wastes can be generated during metal rust prevention and stain removal. Concentrated phenol (heavy metal) wastes resulting from the cleaning of aircraft parts is another example. Chapters 8 and 10 provide waste management guidance for airport and aircraft maintenance shop waste.

12.36.2. Specific Requirements. To address the risk, specific preventive or control requirements in the general permit focus on the storing, handling, and transferring of the Section 313 water priority chemicals (over 200 chemicals) identified as especially toxic to water ecosystems. Table 12-6, which focuses on these toxic chemicals, may be included in SWPPPs of regulated facilities. These actions should help to prevent spills and leaks of water priority chemicals and eliminate or reduce other opportunities for exposure of toxic chemicals to storm water, thus protecting receiving streams from toxic discharges.

12.37. SPECIAL REQUIREMENTS FOR SALT STORAGE PILES. Airports that stockpile salt to deice non-aeronautical operational areas, such as public parking lots or sidewalks, should include in their plan practices which protect the salt stockpile(s) from precipitation. Permits require stockpiles to be either covered or enclosed to prevent exposure to precipitation (except when salt is being added to or taken from the pile) if storm water from a salt stockpile discharges into a receiving body of water. For exterior storage, an inexpensive BMP is the covering of salt piles with tarpaulins or other coverings. AC 150/5220-18 provides guidance on interior storage.

SECTION 7. GENERAL ADMINISTRATIVE REQUIREMENTS

12.38. INTRODUCTION. Permits require four general administrative requirements: (1) compliance and implementation deadlines, (2) required signatures and certifications, (3) availability of the SWPPP for public access, and (4) USEPA required modifications.

12.39. COMPLIANCE DEADLINES. Table 12-5 provides deadlines to develop and implement airport SWPPPs on the basis of when an airport or tenant facility commences regulated industrial activities. Deadlines to complete and comply with or implement a SWPPP (or tenant plan) may depend on two factors: (1) the permit, i.e., general permit under which the airport or tenant facility or activity is covered and, (2) the permitting authority, e.g., Federal or authorized state. Airport authorities should read the permit carefully to determine the deadlines, especially since an authorized state may issue general permits having deadlines different than shown in table 12-5.

Table 12 - 6. Specific Section 313 Facility Controls

<ol style="list-style-type: none"> 1. Provide containment, drainage control, and/or diversionary structures: <ul style="list-style-type: none"> • Prevent or minimize contact with storm water by installing curbing, culverts, gutters, sewers, or other controls, and/or • Prevent or minimize exposure by covering storage piles. 2. Prevent discharges from all areas: <ul style="list-style-type: none"> • Use manually activated valves with drainage controls in all areas, and/or • Equip the areas with a drainage system to detain/retain or treat water priority chemicals. 3. Prevent discharges from liquid storage areas: <ul style="list-style-type: none"> • Store liquid materials in compatible storage containers • Provide secondary containment designed to hold the volume of the largest storage tank plus precipitation. 4. Prevent discharges from loading/unloading areas: <ul style="list-style-type: none"> • Use drip pans and/or • Implement a strong spill contingency and integrity testing plan. 5. Prevent discharges from handling/processing/transferring areas: <ul style="list-style-type: none"> • Use covers, guards, overhangs, door skirts • Conduct visual inspections or leak tests for overhead piping. 6. Introduce facility security programs to prevent spills: <ul style="list-style-type: none"> • Use fencing, lighting, traffic control, and/or secure equipment and buildings.
--

12.40. REQUIRED SIGNATURES. Part VII.G.1 of the general permit requires signatures on all reports, certifications, or information submitted to the permitting authority, submitted to the operator of a large or medium municipal separate storm sewer system, or required to be maintained by the permittee on site. Signature authority falls in one of the following three categories:

12.40.1. For a Federal, state, municipality, or other public agency, the plan should be signed by either the principal executive officer or ranking official, which includes the chief executive officer of the agency, or the senior officer having responsibility for the overall operations of a principal geographic unit of the agency.

12.40.2. For a corporation, the SWPPP should be signed by a "responsible corporate officer." A responsible corporate officer may be any of the following:

12.40.2.1. A president, secretary, treasurer, or vice-president of the corporation in charge of a principal business function, or any other person who performs similar policy or decision-making functions for the corporation.

12.40.2.2. The authority of one or more manufacturing, production, or operating facilities employing more than 250 persons or having gross annual sales or expenditures exceeding \$25,000,000 (in second quarter 1980 dollars) if authority to sign documents has been assigned or delegated to the manager in accordance with corporate procedure.

12.40.3. For a partnership or sole proprietorship, the SWPPP should be signed by a general partner or the proprietor.

12.41. DESIGNATING SIGNATORY AUTHORITY. Any of the above persons may designate a duly authorized representative to sign for them. The representative should have overall responsibility for the operation of the regulated facility or environmental matters for the airport authority or tenant. If an authorized representative is appointed, the authorization should be put in writing by the responsible signatory and submitted to the Director (permitting authority). Any change in authorized representative or an authorized position should be made in writing and submitted to the permitting authority.

12.42. CERTIFICATION STATEMENT REQUIREMENT. To ensure that the airport SWPPP is completely developed and adequately implemented, NPDES permits generally require that an authorized representative sign and certify the plan. The authorized representative should be someone at or near the top of the airport management chain, such as the Director of Operations, Deputy Administrator, or an airport staff manager who has been delegated the authority to sign and certify this type of document.

12.42.1. Signee Responsibilities. In signing the plan, the signee is attesting that the information is true. This signature provides a basis for an enforcement action to be taken against the person signing a plan and related reports. The permittee should be aware that Section 309 of the CWA provides for significant penalties where information is false or the permittee violates, either knowingly or negligently, permit requirements. In some cases, permits may require certification of the SWPPP by a registered professional engineer. Specific signatory requirements will be listed in the NPDES permit.

12.42.2. Certification Statement. Any person signing documents under this section will make the following certification:

"I certify under penalty of law that this document and all attachments were prepared under my direction or supervision in accordance with a system designed to assure that qualified personnel properly gathered and evaluated the information submitted. Based on my inquiry of the person or persons who manage the system, or those persons directly responsible for gathering the information, the information submitted is, to the best of my knowledge and belief, true, accurate, and complete. I am aware that there are significant penalties for submitting false information, including the possibility of fine and imprisonment for knowing violations."
(Part VII.G.2.d)

12.43. SARA TITLE III, SECTION 313 FACILITY PLAN CERTIFICATION REQUIREMENTS. The baseline requirements of the general permit contain additional certification requirements for airport or tenant facilities subject to reporting under SARA Title III, Section 313 for water priority chemicals (Part IV.D.7.b.(10)). The plan should be reviewed and certified by a registered professional engineer and recertified every three years or after the plan is significantly revised. This certification that the airport plan was prepared in accordance with good engineering practices does not relieve the airport authority, as permittee, of the responsibility to prepare and implement the plan.

12.44. AVAILABILITY OF SWPPPS FOR PUBLIC ACCESS. Airport SWPPPs should be maintained on site. The USEPA Director, authorized representative, or the operator of a large or medium

municipal separate storm sewer system may request that the plan be submitted to his or her office. It is advisable, therefore, to have extra copies available. Plans and all required records should be kept at least one year after the permit expires. Plans and associated records are considered to be "reports" pursuant to Section 308(b) of the CWA, and therefore, are available to the public when these documents have been submitted to the Director (permitting authority).

12.45. USEPA DIRECTOR REQUIRED SWPPP MODIFICATIONS. Airport authorities should be aware that, occasionally, plans are requested to be submitted for review to improve them, such as in areas of spill response procedures. Any changes required by the permitting authority must be made within 30 days, unless otherwise provided by notification, and the facility must submit a certification signed in accordance with the general permit, Part VII.G., to the Director (permitting authority) that the requested changes have been made.

APPENDIX A. ACRONYMS AND RELATED READING MATERIAL**A.1. ACRONYMS**

ADF	Average Daily Flow
AC	advisory circular
ACRP	Airport Cooperative Research Program
AVGAS	aviation gasoline
ATU	Aerobic Treatment Unit
BMP	Best Management Practices
BOD ₅	biochemical oxygen demand
CO ₂	carbon dioxide
COD	Chemical Oxygen Demand
CWA	Clean Water Act
CFR	Code of Federal Regulations
CERCLA	Comprehensive Environmental Response, Compensation, and Liability Act
CESQG	Conditionally Exempt Small Quantity Generators
Da	Dalton
DO	dissolved oxygen
EPCRA	Emergency Planning and Community Right-To-Know Act
EMS	Environmental Management system
EPA	Environmental Protection Agency
EG	ethylene glycol
FAA	Federal Aviation Administration
FBO	fixed base operator
FWPP	Foul Weather Procedures Plan
FPD	Freezing Point Depressant

gpd	gallons per day
gph	gallons per hour
gpm	gallons per minute
HAZMAT	Hazardous Material
HC	Hazard Communication
HSWA	Hazardous and Solid Waste Amendments
L	Liter
LQG	Large Quantity Generators
MSDS	material safety data sheet
MSGP	Multi Sector General Permit
NPDES	National Pollutant Discharge Elimination System
NRC	National Response Center
NTIS	National Technical Information Service
NOI	Notice of Intent
NPRM	Notice of Proposed Rule Making
OSHA	Occupational Safety and Health Administration
ppm	parts per million
PPP	pollution prevention plan
PG	propylene glycol
POTW	Publicly Owned Treatment Works
RCRA	Resource Conservation and Recovery Act
RO	reverse osmosis
SBRs	Sequencing Batch Reactors
SQG	Small Quantity Generators
SPCC	Spill Prevention, Control and Countermeasures
SWPPP	Storm Water Pollution Prevention Plan

SSF	subsurface flow
SARA	Superfund Amendments and Reauthorization Act
TKN	Total Kjeldahl Nitrogen
TSS	total suspended solids
TCLP	Toxicity Characteristic Leaching Procedure
TSD	treatment, storage, and disposal
UST	underground storage tank
UST	Underground Storage Tanks
UHW	Uniform Hazardous Waste Manifest
USEPA	United States Environmental Protection Agency
WQA	Water Quality Act of 1987

A.2. RELATED READING MATERIAL

1. *Design of Aircraft Deicing Facilities*, AC 150/5300-14, U.S. Department of Transportation, FAA, Washington, D.C.
2. *Industrial Waste Treatment Handbook*, Second Edition Woodard & Curran, (2006), Boston, New York.
3. *Standard Methods for the Examination of Water, Sewage, and Industrial Wastes*, a joint publication of the American Public Health Association (APHA), the American Water Works Association (AWWA), and the Water Environment Federation (WEF), latest edition, Washington, D.C. This reference is updated approximately every five years.
4. *Hazardous Materials Emergency Planning Guide*, DOT P 5800.4, September 1, 1987, U.S. Department of Transportation, Office of Hazardous Materials Transportation.
5. Campbell, M.E. and W.M. Glenn, *Profit from Pollution Prevention, Pollution Probe Foundation* (1982), Toronto, Ontario, Canada.
6. Patterson, J.W., *Industrial Wastewater Treatment Technology*, 2nd Edition, Butterworth-Heinemann (1985), Boston, Massachusetts.
7. Metcalf & Eddy, Inc., *Wastewater Engineering: Treatment/Disposal/Reuse*, McGraw-Hill (1991), New York, New York.
8. Eckenfelder, W.W., Jr., *Industrial Water Pollution Control*, 2nd Edition, McGraw-Hill (1989), New York, New York.
9. CFR, Title 40 - *Protection of Environment*.

10. USEPA, *Preliminary Data Summary Airport Deicing Operations*, August 2000.
11. *Pretreatment of Industrial Wastes* – Manual of Practice No. FD-3, 1994
12. *Storm water Management For Industrial Activities, Developing Pollution Prevention Plans and Best Management Practices*, September 1992
13. *The Resource Conservation and Recovery Act* (RCRA, 40 CFR (Parts 240 -299) of 1976 as amended by the Hazardous and Solid Waste Amendments of 1984.
14. *Environmental Screening Checklist and Workbook for Airports and Tenant Operations*. Updated July 2000.
15. Publication No. 173- Workshop: *Best Management Practices for Airport Deicing Storm water*, Switzenbaum, M. S. Veltman, T. Schoenberg, C. Durand, D. Mericas, and B. Wagoner, 1999. University of Massachusetts at Amherst, July 28, 1999.
16. University Curriculum Development for Decentralized Wastewater Management, *Aerobic Treatment of Wastewater and Aerobic Treatment Units*, Buchanan and Seabloom, November 2004.

APPENDIX B. FEDERAL PRIORITY POLLUTANT LIST

The following list of pollutants is the Federal priority pollutants list for the year 2007, as given at 40 CFR §403(b).

001. acenaphthene
002. acrolein
003. acrylonitrile
004. benzene
005. benzidine
006. carbon tetrachloride (tetrachloromethane)
007. chlorobenzene
008. 1,2,4-trichlorobenzene
009. hexachlorobenzene
010. 1,2-dichloroethane
011. 1,1,1-trichloroethane
012. hexachloroethane
013. 1,1-dichloroethane haloethers
014. 1,1,2-trichloroethane
015. 1,1,2,2-tetrachloroethane
016. chloroethane
018. bis (2-chloroethyl) ether
019. 2-chloroethyl vinyl ether (mixed)
020. 2-chloronaphthalene
021. 2,4,6-trichlorophenol
022. parachlorometa cresol
023. chloroform (trichloromethane)
024. 2-chlorophenol
025. 1,2-dichlorobenzene
026. 1,3-dichlorobenzene
027. 1,4-dichlorobenzene
028. 3,3-dichlorobenzidine
029. 1,1-dichloroethylene
030. 1,2-trans-dichloroethylene
031. 2,4-dichlorophenol
032. 1,2-dichloropropane
033. 1,2-dichloropropylene (1,3-dichloropropene)
034. 2,4-dimethylphenol
035. 2,4-dinitrotoluene
036. 2,6-dinitrotoluene
037. 1,2-diphenylhydrazine
038. ethylbenzene
039. fluoranthene
040. 4-chlorophenyl phenyl ether
041. 4-bromophenyl phenyl ether
042. bis (2-chloroisopropyl) ether
043. bis (2-chloroethoxy) methane
044. methylene chloride (dichloromethane)
045. methyl chloride (dichloromethane)

- 046. methyl bromide (bromomethane)
- 047. bromoform (tribromomethane)
- 048. dichlorobromomethane
- 051. chlorodibromomethane
- 052. hexachlorobutadiene
- 053. hexachlorocyclopentadiene
- 054. isophorone
- 055. naphthalene
- 056. nitrobenzene
- 057. 2-nitrophenol
- 058. 4-nitrophenol
- 059. 2,4-dinitrophenol
- 060. 4,6-dinitro-o-cresol
- 061. n-nitrosodimethylamine
- 062. n-nitrosodiphenylamine
- 063. n-nitrosodi-n-propylamine
- 064. pentachlorophenol
- 065. phenol
- 066. bis (2-ethylhexyl) phthalate
- 067. butyl benzyl phthalate
- 068. di-n-butyl phthalate
- 069. di-n-octyl phthalate
- 070. diethyl phthalate
- 071. dimethyl phthalate
- 072. 1,2-benzanthracene (benzo(a)anthracene)
- 073. benzo(a)pyrene (3,4-benzo-pyrene)
- 074. 3,4-benzofluoranthene (benzo(b)fluoranthene)
- 075. 11,12-benzofluoranthene (benzo(b)fluoranthene)
- 076. chrysene
- 077. acenaphthylene
- 078. anthracene
- 079. 1,12-benzoperylene (benzo(ghi)perylene)
- 080. fluorine
- 081. phenanthrene
- 082. 1,2,5,6-dibenzanthracene (dibenzo(h)anthracene)
- 083. indeno(1,2,3-cd)pyrene (2,3-o-phenylenepyrene)
- 084. pyrene
- 085. tetrachloroethylene
- 086. toluene
- 087. trichloroethylene
- 088. vinyl chloride (chloroethylene)
- 089. aldrin
- 090. dieldrin
- 091. chlordane (technical mixture and metabolites)
- 092. 4,4-DDT
- 093. 4,4-DDE (p,p-DDX)
- 094. 4,4-DDD (p,p-TDE)
- 095. alpha-endosulfan
- 096. beta-endosulfan
- 097. endosulfan sulfate
- 098. endrin

099. endrin aldehyde
100. heptachlor
101. heptachlor epozide (BHC- hexachlorocyclohexane)
102. alpha-BHC
103. Beta-BHC
104. Gamma-BHC (lindane)
105. Delta-BHC (PCB-polychlorinated biphenyls)
106. PCB-1242 (Arochlor 1242)
107. PCB-1254 (Arochlor 1254)
108. PCB-1221 (Arochlor 1221)
109. PCB-1232 (Arochlor 1232)
110. PCB-1248 (Arochlor 1248)
111. PCB-1260 (Arochlor 1260)
112. PCB-1016 (Arochlor 1016)
113. toxaphene
114. antimony
115. arsenic
116. asbestos
117. beryllium
118. cadmium
119. chromium
120. copper
121. cyanide, total
122. lead
123. mercury
124. nickel
125. selenium
126. silver
127. thallium
128. zinc
129. 2,3,7,8-tetrachloro-dibenzo-p-dioxin (TCDD)

Intentionally left blank.

APPENDIX C. WORKSHEETS FOR SWPPPS

<p>POLLUTION PREVENTION TEAM MEMBER ROSTER</p>	<p>Worksheet #1 Completed by: _____ Title: _____ Date: _____</p>
<p>Leader: _____ Title: _____ Office Phone: _____</p>	
<p>Responsibilities: _____ _____ _____</p>	
<p>Members: (1) _____ Title: _____ Office Phone: _____</p>	
<p>Responsibilities: _____ _____ _____</p>	
<p>(2) _____ Title: _____ Office Phone: _____</p>	
<p>Responsibilities: _____ _____ _____</p>	
<p>(3) _____ Title: _____ Office Phone: _____</p>	
<p>Responsibilities: _____ _____ _____</p>	

<h2 style="margin: 0;">DEVELOPING A SITE MAP</h2>	<p>Worksheet #2 Completed by: _____ Title: _____ Date: _____</p>
<p>Directions: Draw a map of your site including aircraft maneuvering areas, and a footprint of all buildings, structures, paved areas, and parking lots. The information below describes additional elements required by USEPA's General Permit.</p>	
<p>USEPA's General Permit requires that you indicate the following features on your site map:</p> <ul style="list-style-type: none"> • All outfalls and storm water discharges • Drainage areas of each storm water outfall • Structural storm water pollution control measures, such as: <ul style="list-style-type: none"> – Flow diversion structures – Retention/detention ponds – Vegetative swales – Sediment traps • Name of receiving waters (or if through a Municipal Separate Storm Sewer System) • Locations of exposed significant materials • Locations of past spills and leaks • Locations of high-risk, waste generating areas and activities common on industrial sites such as: <ul style="list-style-type: none"> – Fueling areas, fuel farms, stations, and underground systems – Aircraft, pavement deicing/anti-icing areas – Aircraft/vehicle/equipment washing and maintenance areas – Area for unloading/loading materials – Above ground tanks for liquid storage, such as glycol – Industrial waste management areas (waste piles, treatment plants, disposal areas) – Outside storage areas for raw materials, by-products, and finished products – Outside aircraft serving areas – Other areas of concern (specify): 	

<p style="font-size: 1.2em; margin: 0;">MATERIAL INVENTORY</p>	<p>Worksheet #3 Completed by: _____ Title: _____ Date: _____</p>
--	--

Directions:	List all materials used, stored, or produced on site. Assess and evaluate these materials for their potential to contribute pollutants to storm water runoff. Also complete Worksheet 3A if the material has been exposed during the last 3 years.
--------------------	--

Material	Purpose/Location	Quantity (units)			Quantity Exposed in Last 3 Years	Likelihood of contact with storm water. If yes, describe reason.	Past Significant Spill or Leak	
		Used	Produced	Stored			Yes	No

DESCRIPTION OF EXPOSED SIGNIFICANT MATERIAL

Worksheet #3A

Completed by: _____

Title: _____

Date: _____

Directions: Based on your material inventory, describe the significant materials that were exposed to storm water during the past three years and/or are currently exposed. For the definition of "significant materials" see paragraph 12.11.

Description of Exposed Significant Material	Period of Exposure	Quantity Exposed (units)	Location (as indicated on the site map)	Method of Storage or Disposal (e.g., pile, drum, tank)	Description of Material Management Practice (e.g., pile, covered, drum sealed)

LIST OF SIGNIFICANT SPILLS AND LEAKS

Worksheet #4

Completed by: _____

Title: _____

Date: _____

Directions: Record below all significant spills and significant leaks of toxic or hazardous pollutants that have occurred at the facility in the three years prior to the effective date of the permit.

Directions: Significant spills include, but are not limited to, releases of oil or hazardous substances in excess of reportable quantities.

1st Year Prior										
Date (month/day/ year)	Spill	Leak	Location (as indicated on site map)	Description				Response Procedure		Preventive Measures Taken
				Type of Material	Quantity	Source, If Known	Reason	Amount of Material Recovered	Material No Longer Exposed to Storm Water (True/False)	
2nd Year Prior										
Date (month/day/ year)	Spill	Leak	Location (as indicated on site map)	Description				Response Procedure		Preventive Measures Taken
				Type of Material	Quantity	Source, If Known	Reason	Amount of Material Recovered	Material No Longer Exposed to Storm Water (True/False)	
3rd Year Prior										
Date (month/day/ year)	Spill	Leak	Location (as indicated on site map)	Description				Response Procedure		Preventive Measures Taken
				Type of Material	Quantity	Source, If Known	Reason	Amount of Material Recovered	Material No Longer Exposed to Storm Water (True/False)	

**NON-STORM WATER DISCHARGE
ASSESSMENT AND CERTIFICATION**

Worksheet #5

Completed by: _____

Title: _____

Date: _____

Date of Test or Evaluation	Outfall Directly Observed During the Test (Identify as indicated on the site map)	Method Used to Test or Evaluate Discharge	Describe Results from Test for the Presence of Non-Storm Water Discharge	Identify Potential Significant Sources	Name of Person Who Conducted the Test or Evaluation

CERTIFICATION

I, _____ (responsible corporate official), certify under penalty of law that this document and all attachments were prepared under my direction or supervision in accordance with a system designed to assure that qualified personnel properly gather and evaluate the information submitted. Based on my inquiry of the person or persons who manage the system or those persons directly responsible for gathering the information, the information submitted is, to the best of my knowledge and belief, true, accurate, and complete. I am aware that there are significant penalties for submitting false information, including the possibility of fine and imprisonment for knowing violations.

A. Name & Official Title (type or print)	B. Area Code and Telephone No.
C. Signature	D. Date Signed

<h2 style="margin: 0;">NON-STORM WATER DISCHARGE ASSESSMENT AND FAILURE TO CERTIFY NOTIFICATION</h2>		<p>Worksheet #6 Completed by: _____ Title: _____ Date: _____</p>
<p>Directions: If you cannot feasibly test or evaluate an outfall, fill in the table below with the appropriate information and sign this form to certify the accuracy of the included information.</p> <p>List all outfalls not tested or evaluated, describe any potential sources of non-storm water pollution from listed outfalls, and state the reason(s) why certification is not possible. Use the key from you site map to identify each outfall.</p>		
<p>Importance Notice: A copy of this notification must be signed and submitted to the Director within 180 days of the effective date of this permit.</p>		
<p>Identify Outfall Not Tested/Evaluated</p>	<p>Description of Why Certification is Infeasible</p>	<p>Description of Potential Sources of Non-Storm Water Pollution</p>
<p>CERTIFICATION</p>		
<p>I certify under penalty of law that this document and all attachments were prepared under my direction or supervision in accordance with a system designed to assure that qualified personnel properly gather and evaluate the information submitted. Based on my inquiry of the person or persons who manage the system or those persons directly responsible for gathering the information, the information submitted is, to the best of my knowledge and belief, true, accurate, and complete. I am aware that there are significant penalties for submitting false information, including the possibility of fine and imprisonment for knowing violations, and that such notification has been made to the Director (issuing authority) within 180 days of _____ (date permit was issued), the effective date of this permit.</p>		
<p>A. Name & Official Title (type or print)</p>	<p>B. Area Code and Telephone No.</p>	
<p>C. Signature</p>	<p>D. Date Signed</p>	

POLLUTANT SOURCE IDENTIFICATION

Worksheet #7
Completed by: _____
Title: _____
Date: _____

Directions: List all identified storm water pollutant sources and describe existing management practices that address those sources. In the third column, list BMP options that can be incorporated into the plan to address remaining sources of pollutants.

Storm Water Pollutant Sources	Existing Management Practices	Description of New BMP Options
1.		
2.		
3.		
4.		
5.		
6.		
7.		
8.		
9.		
10.		
11.		

BMP IDENTIFICATION

Worksheet #7A

Completed by: _____

Title: _____

Date: _____

Directions: Describe the Best Management Practices (BMPs) that you have selected to include in your plan. For each of the baseline BMPs, describe actions that will be incorporated into the airport or facility operations. Also describe any additional BMPs that you have selected. Attach additional sheets if necessary.

BMPs	Brief Description of Activities
Good Housekeeping	
Preventative Maintenance	
Inspections	
Spill Prevention & Response	
Sediment and Erosion Control	
Management of Runoff	
Additional BMPs (Activity-specific and Site-specific)	

IMPLEMENTATION		Worksheet #8 Completed by: _____ Title: _____ Date: _____		
Directions:	Develop a schedule for implementing each BMP. Provide a brief description of each BMP, the steps necessary to implement the BMP (i.e., any design or construction), the schedule for completing those steps (list dates) and the person(s) responsible for implementation. Attach additional sheets if necessary.			
BMPs	Description of Action(s) Required for Implementation	Scheduled Completion Date(s) for Actions	Person Responsible for Action(s)	Notes
Good Housekeeping	1.			
	2.			
	3.			
Preventative Maintenance	1.			
	2.			
	3.			
Inspections	1.			
	2.			
	3.			
Spill Prevention & Response	1.			
	2.			
	3.			
Sediment and Erosion Control	1.			
	2.			
	3.			
Management of Runoff	1.			
	2.			
	3.			
Additional BMPs (Activity-specific and Site-specific)	1.			
	2.			
	3.			

EMPLOYEE TRAINING		Worksheet #9 Completed by: _____ Title: _____ Date: _____	
Directions: Describe the employee training program for each facility or specific activity. At a minimum the program should, if topics apply, address good housekeeping, spill prevention and response, and material management practices. Provide a schedule for the training program and the roster ID number that lists the employees who attended the training sessions. Attach additional sheets if necessary.			
Training Topics	Brief Description of Training Program and Materials (e.g., posters, newsletters, course, films)	Scheduled for Training (list dates)	Roster ID Number
Good Housekeeping	1.		
	2.		
	3.		
Spill Prevention & Response	1.		
	2.		
	3.		
Material Management Practices	1.		
	2.		
	3.		
Other Topics	1.		
	2.		
	3.		
	1.		
	2.		
	3.		
	1.		
	2.		
	3.		

PAVEMENT DEICING/ANTI-ICING RELEASES

Worksheet #10

Completed by: _____

Title: _____

Date: _____

Directions: Record the releases of pavement deicing/anti-icing chemicals as an aggregate of all deicing/anti-icing operations that occur during a 24 hour period. Attach additional sheets if necessary. (Information still needed for quantities used by airlines and other tenants).

Date (Event Number#)	Location (rwy/twy/apron)	Type of Deicing/Anti-icing Product (by trade name)	Estimated Quantity (gallons)	Estimated Quantity (tons)	Comments
	1.				
	2.				
	3.				
	1.				
	2.				
	3.				
	1.				
	2.				
	3.				
	1.				
	2.				
	3.				
	1.				
	2.				
	3.				

APPENDIX D. SAMPLE OF AN AIRPORT SWPPP

1. SWPPP SAMPLE. This sample shows how information for a SWPPP may be organized. The SWPPP is developed for the entire site and it includes, in Appendix E, an attached supplemental plan of an airport tenant metal plating industry located on the property. This sample assumes that the airport authority and the tenant share a drainage area (outfall no. 6) and are co-permittees. The sample is designed as an active document that is easily updated. Updated information typically includes revisions to the exposed material inventory, inspection reports, implementation and training schedules, and SWPPP revisions.

STORM WATER POLLUTION**PREVENTION PLAN****COUNTY AIRPORT**

100 Airline Drive

Silverton City, Texas

December 2008

Emergency Contact: Bethel Burson Turner

Title: Airport Manager

Phone: 904-267-8766

I. PLANNING AND ORGANIZATION

- A. Member Roster (worksheet No. 1)
- B. Consistency with Other Plans

II. SITE ASSESSMENT

- A. Site Map (worksheet No. 2)
- B. Inventory of Materials.
 - 1. Description of Exposed Materials (worksheet No. 3)
 - 2. Description of Exposed Significant Materials (worksheet No. 3A)
- C. Past Spills and Leaks (worksheet No. 4)
- D. Non-storm Water Discharges (worksheet No. 5)
- E. Non-storm Water Discharges - Failure to Certify (worksheet No. 6)
- F. Storm Water Sampling Data
 - 1. Sampling Records
 - 2. Alternative Certification
- G. Risk Identification and Potential Pollutant Sources
 - 1. Pollutant Source Summary (worksheet No. 7)
 - 2. Site Assessment Report

III. PLAN DESIGN - BMP SELECTION

- A. Baseline BMP Narrative Summary (worksheet No. 7A)
 - 1. Good Housekeeping
 - 2. Preventive Maintenance
 - 3. Visual Inspections
 - 4. Spill Prevention and Response
 - 5. Sediment and Erosion Control
 - 6. Management of Runoff

B. Activity Specific BMPs

1. Vehicle Fueling Areas.
2. Vehicle Sump Fuel Storage Areas.
3. Deicing/anti-icing.
4. Oil Barrel Storage Areas.
5. Aircraft Exterior Cleaning Activities.

IV. IMPLEMENTATION SCHEDULE

- A. BMP Schedule Summary (worksheet No. 8)
- B. Employee Training Schedules (worksheet No. 9)

V. SWPPP EVALUATION

- A. Annual Compliance Evaluation Reports
- B. Inspection and Maintenance Reports
- C. Plan Revisions

VI. GENERAL REQUIREMENTS

- A. Required Signatures
- B. Plan Location and Public Access
- C. USEPA Director Required Plan Modification

VII. SPECIAL REQUIREMENTS

- A. Discharges Through a Municipal Separate Storm Water System (MS4)
- B. Discharges From Facilities Subject to Reporting Under EPCRA Section 313

ATTACHMENT No. 1: NPDES General Permit for Storm Water Discharges Associated with Industry Activities. The SWPPP does not require an attached copy of the permit (omitted for this sample).

ATTACHMENT No. 2: Special Requirements for Metalplate, Inc. (a fictitious corporation), an EPCRA Section 313 Facility (see Appendix E).

I. PLANNING AND ORGANIZATION

- A. Member Roster. See attached worksheet No. 1 for pollution prevention plan team members.
- B. Consistency with Other Plans.

The county airport has a Spill Prevention Control and Countermeasures (SPCC) Plan and a Foul Weather Procedures Plan (FWPP) in place. The airport tenant, Metalplate, Inc., has a separate SWPPP and a SPCC plan, developed specifically for their site operations. Overlaps between these existing plans and airport SWPPP are noted below:

Responsibility for executing each of the environmental plans (SWPPP and SPCC) is shared between the airport authority and the tenant (Metalplate, Inc.).

The spill prevention and response measures for the airport SWPPP are adopted from the SPCC plans for both airport authority and tenant.

II. SITE ASSESSMENT

A. Site Map. See attached map and the accompanying checklist, worksheet No. 2.

B. Inventory of Exposed Materials.

1. All materials that are stored onsite that are exposed to precipitation (potential to contribute pollutants to storm water runoff) are listed on worksheet No. 3.
2. Significant materials that are exposed to precipitation during the three years prior to the date of the permit are listed on worksheet No. 3A.

C. Past Spills and Leaks. See worksheet No. 4.

D. Non-storm Water Discharges. See worksheet No. 5.

E. Non-storm Water Discharges - failure to certify. See worksheet No. 6.

F. Storm Water Sampling Data. Use this section to keep storm water sampling data. Since this airport has over 50,000 flight operations per year, the outfalls that convey storm water discharges from deicing/anti-icing areas must be either sampled or certified (Section II, F.2) annually.

1. Sample records and lab results. See attached memorandum dated 11/20/93, after worksheet no. 5, that presents laboratory results.
2. Alternative Certification. Refer to Part VI.B.7 of the general permit (Attachment 1). If dischargers can certify for a given outfall that no exposure of significant materials occurs within the outfall drainage area, the discharge is not subject to monitoring requirements.

G. Risk Identification and Potential Pollutant Sources

1. Pollutant Source Summary, see worksheet No. 7.
2. Site Assessment Report, see following report.

SITE ASSESSMENT REPORT

A site assessment inspection must be performed to identify any potential pollutant source on airport property. This section presents a summary assessment of the industrial activities and the potential for exposure of significant materials in the drainage areas covered by the NPDES storm water discharge permit. Worksheet No. 7 may be used to summarize the assessments of pollutant sources

and the corresponding storm water management practices. In each sample, a narrative summary is presented below, in addition to the abbreviated worksheet summary.

Fuel Handling

The aviation fuel farm is located on the south end of the airfield adjacent to Hanger 28S. There are two 10,000-gallon (37,854 L) above ground storage tanks with secondary containment provided by concrete dike walls. There were minor fuel stains on the ground within the curbed fuel loading and unloading areas. Otherwise, there did not appear to be a significant potential for exposure of aviation fuel to storm water runoff.

The refueling trucks are kept parked north of Hanger 1S. The truck parking area was clean and there were only minor signs of oil and fuel leaks.

Sump fuel is stored in a 250-gallon (946 L) above ground tank adjacent to the refueling truck parking area. There were minor fuel stains on the pavement within the curbed loading and unloading areas. Otherwise, there did not appear to be significant exposure of fuels from the sump fuel tank truck parking areas to storm water runoff.

Unleaded gasoline for vehicles is stored adjacent to hanger 16S in a 1,000-gallon (3,785 L) above ground tank. Secondary containment is provided by concrete curbing.

Hanger 8S

Aircraft are service and repaired at this facility. The following significant materials are stored outdoors:

2 Waste oil drums, 55 gallons (208 L) each.

The drums are kept closed and the waste oil is pumped from the drums every six months. No secondary containment is provided.

The following significant materials are stored on covered racks outside of the Hanger:

1 mineral spirits (liquid), 55 gallons (208 L).

1 stripper (liquid), 300 gallons (1,136 L) above ground tank

1 mild soap, 1 gallon (3.78 L) container

degreasers and paints, small quantities

The tank with stripping agent is sealed and it is refilled approximately once every two years.

Approximately 3 to 4 aircraft per month are washed outside the hanger using a mild detergent. The waste wash water evaporates on the apron.

Hanger 10S

This hanger is leased to a private drilling company and it is used for maintenance and storage of drilling vehicle. No significant materials are stored outside and there does not appear to be potential for exposure of significant materials to storm water.

Hanger 18S

A 55-gallon (208 L) barrel of hydraulic oil is stored outside under cover. No secondary containment is provided.

Aircraft Paint Services Hanger 6N

All work is performed in the hanger. Paint is only purchased in the amount needed for each job. Paint solvents are stored in small containers and there is generally less than 20 gallons (76 L) stored.

Aircraft Wash Racks Hanger 6N

There are three wash racks for cleaning aircraft and vehicles. The racks are drained through a sand box and oil separator, prior to discharge to the city's storm sewer system.

Deicing/Anti-icing Operations

Areas used for deicing/anti-icing aircraft are shown on the site map. Aircraft and pavement deicing/anti-icing activities are routinely performed during winters. For pavement activities, see worksheet No. 10, Pavement Deicing Chemical Release Log. For aircraft activities, some deicing is required during summer months for certain aircraft. A mixture of ethylene based glycol is the primary deicing/anti-icing chemical used for aircraft and potassium acetate for runways. In the past, there were no measures in place to monitor or control these fluids in storm water runoff. Since more than 50,000 flight operations are performed annually, storm water monitoring will be required to comply with the NPDES storm water permit. Controls to limit the BOD₅ impact of deicers/anti-icers on receiving bodies of waters will be selected as part of the airport master drainage plan update. The preliminary BMPs being considered for control of deicing/anti-icing fluids are:

- Sweeper/vacuum trucks
- Aircraft deicing/anti-icing locations with collection drains
- Retention ponds

Metalplate Inc. (Building 45S)

Metalplate, Inc., a tenant, is subject to EPCRA Section 313 reporting requirements. The airport and tenant have a co-permittee agreement for outfall No. 6. The tenant's SWPPP special requirements for EPCRA reporting facilities are addressed in attachment 2 of the airport's SWPPP. See attachment 2 for the Metalplate, Inc., Site Assessment and other specific plan information (Appendix E of this AC).

All areas described above will be included in periodic and annual compliance inspections as required by the NPDES Storm Water Discharge Permit.

III. PLAN DESIGN - BMP SELECTION

A. Baseline BMP Narrative Summary (see worksheet 7A). In addition, baseline BMPs for Metalplate, Inc., are outlined in attachment 2 of this plan.

1. Good Housekeeping. Vacuum sweeper trucks follow a daily schedule on all paved areas. The vehicle maintenance shops are cleaned daily and minor spills of fuel and oil products are

cleaned immediately. Discarded shipping materials are either recycled or disposed in dumpsters which are emptied weekly.

2. Preventive Maintenance. Catch basins and oil/water separators are inspected and cleaned after heavy rains and snow events. Fuel handling trucks and equipment are visually inspected daily for leaks. Equipment valves and connections are routinely tested according to the manufacturer's recommendations. The airport and tenants will inspect their own equipment and deicing trucks on a seasonal schedule. Fuel, oil, and deicing chemical storage facilities are routinely inspected for leaks.

3. Visual Inspections. Dee McCandless, Operations Coordinator, is responsible for maintaining a qualified inspection and maintenance staff. She receives all inspection and maintenance reports and keeps a log of follow-up activities. Inspection and maintenance records of storm water control facilities are filed in Section V.B of this plan.

4. Spill Prevention and Response. Spills that may impact storm water quality would primarily involve the fuel handling, oil storage, deicing/anti-icing activities, vehicle/aircraft maintenance operations. The site map building reference shows the locations of these activities. Aviation fuel spills and ground vehicle fuel spills that occur in the storage and loading and unloading areas would drain to Outfall No. 8. Oil and pavement deicing chemical drum storage locations are referenced in Section II.G.2 of this document. The discharge points for each of these storage locations are referenced on the site map. Spills that occur while fueling or deicing/activities aircraft will drain according to the site map drainage area delineations.

Fuel and oil spill clean up procedures are defined in the Fuel Spill Contingency Plan. Equipment and personnel requirements are addressed in the Contingency Plan. Deicing/anti-icing chemical spill prevention and response procedures are being developed in conjunction with the Drainage Master Plan Update which will outline the new runway deicing/anti-icing application procedures. Air carriers will integrate their aircraft ground deicing/anti-icing plan.

5. Sediment and Erosion Control. All unpaved areas are planted with grasses and ground covers to limit erosion. Silt fencing is used during minor site work and pavement repairs. When construction activities that involve five acres or more of land disturbance a NOI will be filed for coverage under the NPDES General Permit for storm water associated with construction activities. For this case, a separate "construction activity" SWPPP will be developed to address the requirements under this type of permit.

6. Management of Runoff. Storm water runoff is directed to 11 discharge points, located along the airport property line. Roughly five percent of the runoff is directed to a municipal storm sewer system, operated by the Town of Silverton City. The receiving waters for these outfalls are Bare Creek and Burson Creek.

The airport drainage system includes a series of catch basins and concrete storm sewers that direct runoff away from the paved areas toward the outfalls and City's storm sewer outfall. Oil/water separators are installed in each of the inlets that drain the apron and hanger areas. Unpaved areas are grassed to prevent erosion.

Storm water runoff that would contain deicing/anti-icing chemicals drains to outfall Nos. 3, 6, 8 and 10. A storm water sampling program is being developed for these outfalls. The results

of the sampling program will be used to design any specific BMPs for control of storm water that contain these chemicals.

B. Activity Specific BMPs

1. Fuel loading and unloading areas will be equipped with drip pads to prevent accumulations of fuel on the pavement in these areas.
2. Sump fuel storage area will be equipped with a drip pad.
3. Specific BMPs for deicing/anti-icing areas will be designed upon review of storm water sampling data and recommendations of the master drainage plan update.
4. Concrete curbing will be placed around outdoor oil barrel storage areas.
5. Sand filter drains may be installed for the aircraft cleaning activities adjacent to Hanger 8S. Otherwise these activities may be moved to the existing wash rack facilities.

IV. IMPLEMENTATION SCHEDULE

- A. BMP Schedule Summary. See worksheet No. 8, attached.
- B. Employee Training Schedules. See worksheet No. 9, attached.

V. SWPPP EVALUATION

A. Annual Site Compliance Evaluation Reports. Use this section to keep the annual reports. The evaluation report will cover the entire airport site, including the tenant facilities. The following is an outline of the Annual Site Compliance Report requirements:

1. Scope of evaluation (describe areas and activities evaluated).
2. List of qualified persons performing the evaluation.
3. Dates of the evaluation inspection.
4. Major observations relating to the plan implementation and effectiveness.
5. Recommended actions.
6. Incidents of noncompliance with plan.
7. Certification of compliance with the SWPPP and Permit. 8. Certification signatures.

B. Inspection and Maintenance Reports.

Use this section to keep records of inspections and maintenance activities related to storm water controls and measures.

C. Plan Revisions.

Use this section to document revisions to the plan

GENERAL REQUIREMENTS

A. Required Signatures

Any person signing documents under this permit will make the certification that is contained in the Permit, Part VII.G.2.d. (See Attachment 1, NPDES General Permit).

B. Plan Location and Public Access

The plan is required to be maintained on site (airport) unless the USEPA or the operator of a large or medium municipal separate storm sewer system (see section VII.A.) requests that the plan be submitted for review.

C. USEPA Director-Required Plan Modifications

Any changes required by the permitting authority must be made within 30 days, unless otherwise provided by the notification, and the airport authority must submit a certification signed in accordance with Permit, Part VII G., to the USEPA Director that the requested changes have been made.

VII. SPECIAL REQUIREMENTS

A. Additional Requirements for Storm Water Discharges Associated with Industry Activity through Separate Storm Sewer Systems.

Provide a section to include applicable requirements of the municipal storm sewer system that receives airport storm water runoff. The municipal storm sewer system requirements are applicable if the system serves a population of 100,000 or more. In this case, a copy of the airport's NOI for permit coverage must be submitted to the municipal system operator, and a copy of the airport SWPPP must be submitted to the municipal operator upon request.

B. Additional Requirements for Storm Water Discharges Associated with Industrial Activities from Facilities Subject to EPCRA Section 313 Requirements.

For those tenants who are reporting under EPCRA Section 313 for chemicals that are classified as "water priority chemicals," in accordance with the definition in Part X of the general permit, the following special requirements must be addressed in the airport's SWPPP.

1. Pollution Prevention Team. The team must designate a person who will be accountable for spill prevention.
2. Preventive Maintenance. The facility plan must specify maintenance schedules related to preventing leaks and other avenues of contact between water priority chemicals and storm water runoff. Corrective action must take place immediately, once threatening conditions are found.
3. Spill Prevention and Response Procedures. When a leak or spill of a water priority chemical has occurred, the contaminated soil, material, or debris must be removed promptly and disposed in accordance with Federal, state, and local requirements. These facilities are required to designate a person responsible for spill prevention response and reporting procedures.

4. Employee Training. Annual training is required on each of the following topics:

- Preventive maintenance and spill prevention and response.
- Pollution control laws and regulations.
- The facility's overall pollution prevention plan.
- Features and operations designed to minimize discharges of water priority chemicals.

5. Professional Certification. The facility plan must be reviewed and certified by a registered professional engineer. The facility plan must be recertified every three years or after the plan has been significantly changed.

<p>POLLUTION PREVENTION TEAM</p> <hr/> <p>MEMBER ROSTER</p>	<p>Worksheet #1 Completed by: <u>Bethel Burson Turner</u> Title: <u>Airport Manager</u> Date: <u>Nov 12, 2008</u></p>
<p>Leader: <u>Bethel Burson Turner</u> <hr/> Title: <u>Airport Manager</u> Office Phone: <u>(904) 267-8766</u></p>	
<p>Responsibilities: Signatory authority; coordinates all stages of plan development and implementation for all airport and tenant (co-permittee) facilities; coordinate employee training programs; keeps all records and ensures reports are submitted.</p>	
<p>Members:</p>	
<p>(1) <u>Ms. Dee McCandless</u></p>	<p>Title: <u>Airport Operations Coordinator</u> Office Phone: <u>(904) 267-4442</u></p>
<p>Responsibilities: Overall plan assessment and design, storm water monitoring, spill response coordinator. Conduct employee training on storm water related topics.</p>	
<p>(2) <u>Mr. Gene Menger</u></p>	<p>Title: <u>Plant Manager, Metalplate, Inc.</u> Office Phone: <u>(904) 267-8200</u></p>
<p>Responsibilities: Signatory authority for co-permittee, Metalplate, Inc. Coordinates with airport authority. Responsible for tenant plan's special requirements related to EPCRA Section 313 reporting facility. Coordinates spill prevention and response for Metalplate, Inc. site. See Attachment No. 2 for tenant plan.</p>	
<p>(3) _____</p>	<p>Title: _____ Office Phone: _____</p>
<p>Responsibilities: _____ _____</p>	
<p>(4) _____</p>	<p>Title: _____ Office Phone: _____</p>
<p>Responsibilities: _____ _____</p>	

<h2 style="margin: 0;">DEVELOPING A SITE MAP</h2>	<p>Worksheet #2 Completed by: <u>Dee McCandless</u> Title: <u>Operations Coordinator</u> Date: <u>Dec 10, 2008</u></p>
<p>Directions: Draw a map of your site including aircraft maneuvering areas, and a footprint of all buildings, structures, paved areas, and parking lots. The information below describes additional elements required by USEPA's General Permit.</p>	
<p>USEPA's General Permit requires that you indicate the following features on your site map:</p> <ul style="list-style-type: none"> • All outfalls and storm water discharges • Drainage areas of each storm water outfall • Structural storm water pollution control measures, such as: <ul style="list-style-type: none"> – Flow diversion structures – Retention/detention ponds – Vegetative swales – Sediment traps • Name of receiving waters (or if through a Municipal Separate Storm Sewer System) • Locations of exposed significant materials • Locations of past spills and leaks • Locations of high-risk, waste generating areas and activities common on industrial sites such as: <ul style="list-style-type: none"> – Fueling areas, fuel farms, stations, and underground systems – Aircraft, pavement deicing/anti-icing areas – Aircraft/vehicle/equipment washing and maintenance areas – Area for unloading/loading materials – Above ground tanks for liquid storage, such as glycol – Industrial waste management areas (waste piles, treatment plants, disposal areas) – Outside storage areas for raw materials, by-products, and finished products – Outside aircraft serving areas – Other areas of concern (specify): <u>BLDG 45S, Metalplate, Inc.</u> 	

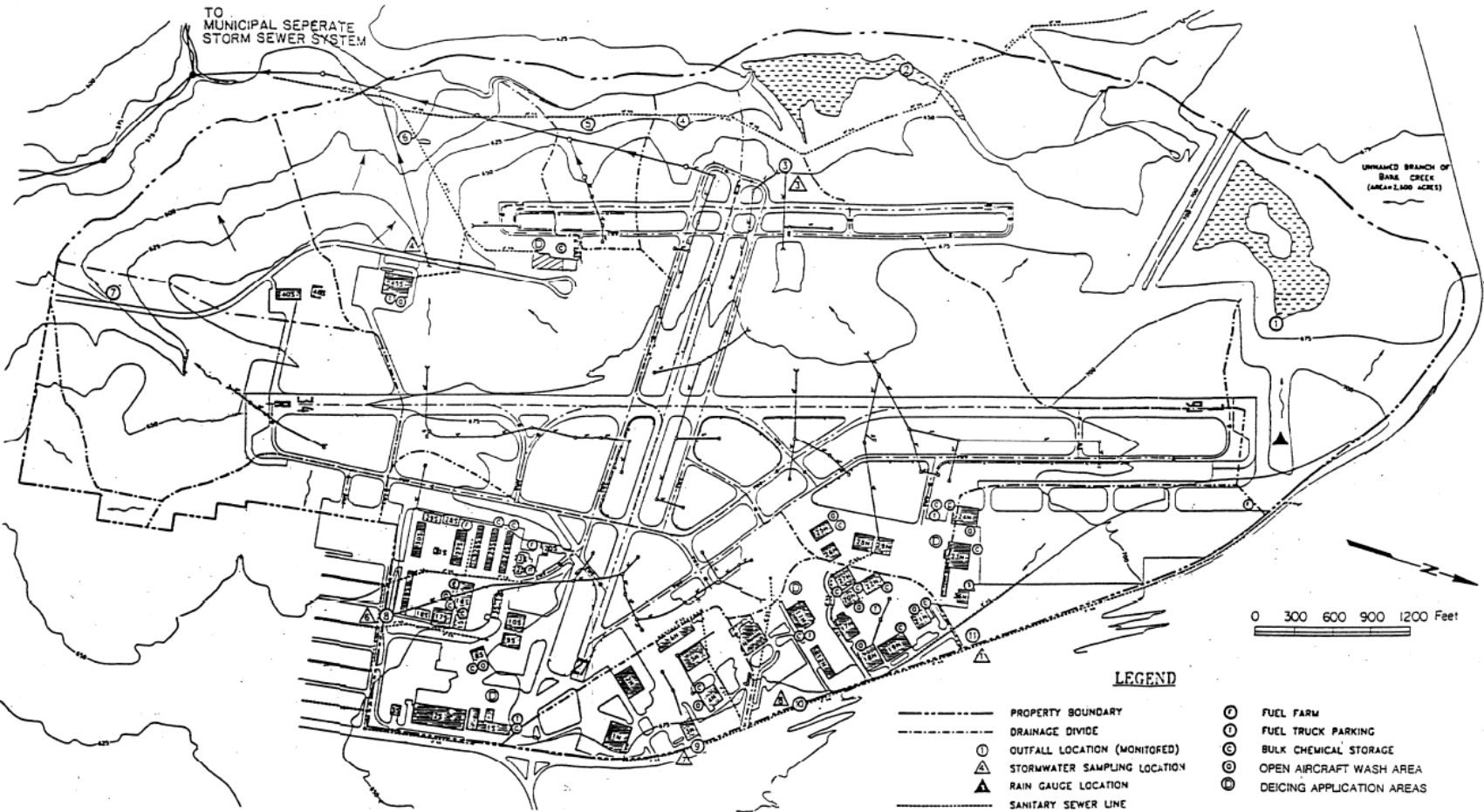

BUILDING REFERENCE

1S Jet Aviation	24S Leased T-Hangars	5N Empty	27N Resources
2S Flight Training	25S Leased T-Hangars	6N Contract Aircraft Painting	28N Aircraft
3S Fire Station	26S Leased T-Hangars	11N Jet Fuel	29N Jet Hanger
8S Tex Air	28S Airplane Factory	12N Aviation	36N Air Industries
9S Empty	29S Aircraft Paint Services	17N Jet Hanger	
10S Drilling Co.	30S Leased T-Hangars	18N Jet Hanger	
15S Advanced Aviation	31S Aircraft Sales	19N Air Center	
16S Hawk Airlines	40S Aviation	20N Aviation	
17S Empty	45S Metalplate, Inc.	21N Holding	
18S T. Products	48S Empty	22N Companies	
19S Leased T-Hangars	1N Flight Center	23N Jet Hanger	
20S Fire Station	2N Aircraft	24N Instruments	
22S Lubricants	3N Tech Avionics	25N Railroad	
23S Lubricants	4N Avionics	26N Jet Hanger	

County Airport
Silverton City, Texas
December 3, 2007

MATERIAL INVENTORY

Worksheet #3

Completed by: Dee McCandless

Title: Operations Coordinator

Date: Dec 12, 2008

Directions:

List all materials used, stored, or produced on site. Assess and evaluate these materials for their potential to contribute pollutants to storm water runoff. Also complete Worksheet 3A if the material has been exposed during the last 3 years.

Material	Purpose/Location	Quantity (units)			Quantity Exposed in Last 3 Years	Likelihood of contact with storm water. If yes, describe reason.	Past Significant Spill or Leak	
		Used	Produced	Stored			Yes	No
Jet A, A-1 Fuels	28S			10		Possible during aircraft fueling		x
Avgas 80, 100, 100 LL	28S			10		Possible during aircraft fueling		x
Sump Fuel	1S			0.25		Possible during tank filling		x
Waste oil	8S			0.11		Possible during tank filling		x
Ethylene glycol	1S,11N,23N, and WMF ramp			20.0		Exposure during each operation at all deicing/anti-icing areas, rwy, twys.	x	
Unleaded gasoline	16S			1.0		Possible during fuelling		x
Mineral Spirits	8S			0.055		Only during uncontrolled spill; no secondary containment		x
Stripper	8S			0.30		Yes, evaporates on pavement		x
Mild Soap	8S			-		Only during uncontrolled spill; no secondary containment		x
Degreasers, Paints	8S			-		Only during uncontrolled spill; no secondary containment		x
Water Methanol	18S			0.11		Only during uncontrolled spill; no secondary containment		x
Engine Oil	18S			0.055		Only during uncontrolled spill; no secondary containment		x
Soap	18S			0.055		Only during uncontrolled spill; no secondary containment		x
Paints, Solvents	6N			-		Only during uncontrolled spill; no secondary containment		x
Varsol Naphtha	6N			0.20		Only during uncontrolled spill; no secondary containment		x

9/8/2008

AC 150/5320-15A
Appendix D

DESCRIPTION OF EXPOSED SIGNIFICANT MATERIAL

Worksheet #3A

Completed by: Dee McCandless

Title: Operations Coordinator

Date: Dec 2, 2008

Directions: Based on your material inventory, describe the significant materials that were exposed to storm water during the past three years and/or are currently exposed. For the definition of "significant materials" see advisory circular.

Description of Exposed Significant Material	Period of Exposure	Quantity Exposed (units)	Location (as indicated on the site map)	Method of Storage or Disposal (e.g., pile, drum, tank)	Description of Material Management Practice (e.g., pile, covered, drum sealed)
Ethylene glycol	intermittent	20,000 gal	all apron areas	dilution in runoff	See Drainage Master Plan
Soap	intermittent	---	aircraft wash racks	evaporation	Sand filter drains

9/8/2008

AC 150/5320-15A
Appendix D

LIST OF SIGNIFICANT SPILLS AND LEAKS

Worksheet #4

Completed by: Dee McCandless

Title: Operations Coordinator

Date: Dec 2, 2008

Directions: Record below all significant spills and significant leaks of toxic or hazardous pollutants that have occurred at the facility in the three years prior to the effective date of the permit.

Directions: Significant spills include, but are not limited to, releases of oil or hazardous substances in excess of reportable quantities.

1st Year Prior										
Date (month/day/ year)	Spill	Leak	Location (as indicated on site map)	Description				Response Procedure		Preventive Measures Taken
				Type of Material	Quantity	Source, If Known	Reason	Amount of Material Recovered	Material No Longer Exposed to Storm Water (True/False)	
2006	x		all aprons	Ethylene glycol	7,000 gal	deicing trucks	aircraft icing	--	F	use as needed
2nd Year Prior										
Date (month/day/ year)	Spill	Leak	Location (as indicated on site map)	Description				Response Procedure		Preventive Measures Taken
				Type of Material	Quantity	Source, If Known	Reason	Amount of Material Recovered	Material No Longer Exposed to Storm Water (True/False)	
2007	x		all aprons	Ethylene glycol	9,000 gal	deicing trucks	aircraft icing	--	F	use as needed
3rd Year Prior										
Date (month/day/ year)	Spill	Leak	Location (as indicated on site map)	Description				Response Procedure		Preventive Measures Taken
				Type of Material	Quantity	Source, If Known	Reason	Amount of Material Recovered	Material No Longer Exposed to Storm Water (True/False)	
2008	x		all aprons	Ethylene glycol	7,800 gal	deicing trucks	aircraft icing	--	F	use as needed

NON-STORM WATER DISCHARGE ASSESSMENT AND CERTIFICATION			Worksheet #5 Completed by: <u>Dee McCandless</u> Title: <u>Operations Coordinator</u> Date: <u>Dec 20, 2008</u>		
Date of Test or Evaluation	Outfall Directly Observed During the Test (Identify as indicated on the site map)	Method Used to Test or Evaluate Discharge	Describe Results from Test for the Presence of Non-Storm Water Discharge	Identify Potential Significant Sources	Name of Person Who Conducted the Test or Evaluation
11/19/2008	Outfall No. 8	Field water quality test	See attached report on water quality analysis. Test indicates groundwater.	jet fuel	McCandless
11/16/2008	Outfall Nos. 1-7, 9-11	visual	no discharge observed		McCandless
note:	Outfall No. 6 is a discharge point for Metalplate, Inc. Since this tenant industry uses water priority chemicals and reports under EPCRA Section 313, the certification for this discharge point is provided by a registered professional engineer.				
CERTIFICATION					
I, <u>Walter M. Frucht</u> (responsible corporate official), certify under penalty of law that this document and all attachments were prepared under my direction or supervision in accordance with a system designed to assure that qualified personnel properly gather and evaluate the information submitted. Based on my inquiry of the person or persons who manage the system or those persons directly responsible for gathering the information, the information submitted is, to the best of my knowledge and belief, true, accurate, and complete. I am aware that there are significant penalties for submitting false information, including the possibility of fine and imprisonment for knowing violations.					
A. Name & Official Title (type or print) <u>Walter M. Frucht, P.E.</u>				B. Area Code and Telephone No. <u>(904) 267-8761</u>	
C. Signature				D. Date Signed <u>Dec. 20, 2008</u>	

MEMORANDUM REPORT

FROM: Dee McCandless

TO: Bethel Burson Turner

DATE: 11/20/2007

SUBJECT: Non-storm Water Discharges at Outfall No. 8.

DATE OF SAMPLING: 11/19/2007

Parameter	Quantity	Sample Type
pH	8.1	grab
Total Copper	0.0 ppm	
Phenols	<0.1 ppm	
Total Res. Chlorine	<0.1 ppm	
Detergents	0.2 ppm	
Boryer Color	#93 (transparent)	
Oil and Grease	0.0 ppm	

<h2 style="margin: 0;">NON-STORM WATER DISCHARGE ASSESSMENT AND FAILURE TO CERTIFY NOTIFICATION</h2>	<p>Worksheet #6 Completed by: <u>Dee McCandless</u> Title: <u>Operations Coordinator</u> Date: <u>Dec 11, 2008</u></p>	
<p>Directions: If you cannot feasibly test or evaluate an outfall, fill in the table below with the appropriate information and sign this form to certify the accuracy of the included information.</p> <p>List all outfalls not tested or evaluated, describe any potential sources of non-storm water pollution from listed outfalls, and state the reason(s) why certification is not possible. Use the key from you site map to identify each outfall.</p>		
<p>Importance Notice: A copy of this notification must be signed and submitted to the Director within 180 days of the effective date of this permit.</p>		
<p>Identify Outfall Not Tested/Evaluated</p>	<p>Description of Why Certification is Infeasible</p>	<p>Description of Potential Sources of Non-Storm Water Pollution</p>
<p>ALL OUTFALLS TESTED</p>		
<p>CERTIFICATION</p>		
<p>I certify under penalty of law that this document and all attachments were prepared under my direction or supervision in accordance with a system designed to assure that qualified personnel properly gather and evaluate the information submitted. Based on my inquiry of the person or persons who manage the system or those persons directly responsible for gathering the information, the information submitted is, to the best of my knowledge and belief, true, accurate, and complete. I am aware that there are significant penalties for submitting false information, including the possibility of fine and imprisonment for knowing violations, and that such notification has been made to the Director (issuing authority) within 180 days of _____ (date permit was issued), the effective date of this permit.</p>		
<p>A. Name & Official Title (type or print) Bethel Burson Turner</p>		<p>B. Area Code and Telephone No. (904) 267-8766</p>
<p>C. Signature</p>		<p>D. Date Signed 12/9/2008</p>

POLLUTANT SOURCE IDENTIFICATION

Worksheet #7

Completed by: Dee McCandless

Title: Operations Coordinator

Date: Dec 11, 2008

Directions: List all identified storm water pollutant sources and describe existing management practices that address those sources. In the third column, list BMP options that can be incorporated into the plan to address remaining sources of pollutants.

Storm Water Pollutant Sources	Existing Management Practices	Description of New BMP Options
1. Fuel handling adjacent to tank farm	Concrete curbing	Add drip pads to prevent fuel from accumulating on pavement
2. Sump (waste) fuel storage area	Concrete curbing	Add drip pads, per item 1.
3. Hanger 8S - aircraft washing area	none	Sand filter drains or abandon hanger 8S wash operations and move to wash racks
4. Aircraft deicing/anti-icing areas	none	Sweeper/vacuum trucks, designated deicing/anti-icing areas, retention ponds
5. Hangers 8S, 12S - oil storage		Install concrete curbing for secondary containment
6.		
7.		
8.		
9.		
10.		

BMP IDENTIFICATION

Worksheet #7A

Completed by: Dee McCandless

Title: Operations Coordinator

Date: Dec 11, 2008

Directions: Describe the Best Management Practices (BMPs) that you have selected to include in your plan. For each of the baseline BMPs, describe actions that will be incorporated into the airport or facility operations. Also describe any additional BMPs that you have selected. Attach additional sheets if necessary.

BMPs	Brief Description of Activities
Good Housekeeping	Add drip pads at the refueling truck loading and unloading areas.
Preventative Maintenance	Routine inspection of storm water inlet controls, fuel handling areas (such as oil/water separators), and other outdoor material storage facilities.
Inspections	Routine inspection of all significant materials handling in the areas regulated by the permit.
Spill Prevention & Response	Continue existing program and include methods for controlling runoff that contains deicing/anti-icing fluids during storm events.
Sediment and Erosion Control	All unpaved areas are grassed or planted with ground cover.
Management of Runoff	Implement storm water monitoring activities at outfalls serving the areas where deicing/anti-icing takes place.
Additional BMPs (Activity-specific and Site-specific)	Continue investigation of storm water controls for the deicing/anti-icing areas.

IMPLEMENTATION		Worksheet #8		
		Completed by: <u>Dee McCandless</u>		
		Title: <u>Operations Coordinator</u>		
		Date: <u>Dec 11, 2008</u>		
Directions: Develop a schedule for implementing each BMP. Provide a brief description of each BMP, the steps necessary to implement the BMP (i.e., any design or construction), the schedule for completing those steps (list dates) and the person(s) responsible for implementation. Attach additional sheets if necessary.				
BMPs	Description of Action(s) Required for Implementation	Scheduled Completion Date(s) for Actions	Person Responsible for Action(s)	Notes
Good Housekeeping	1. Install fuel handling drip catch basins	12/18/08	Doug Flannigan	
	2. Develop training program	2/1/09	Nick Colin	
	3. Conduct training	4/1/09	Nick Colin	New employees
Preventative Maintenance	1. Routine inspection of storm water controls	ongoing	Dee McCandless	
	2.			
Inspections	1. Develop schedule for inspection of storm water controls	2/1/09	Carol Cook	
Spill Prevention & Response	1. Develop training schedule	2/1/09	Colleen Quinn	
	2. Conduct training	4/1/09	Colleen Quinn	Annual update
Sediment and Erosion Control	1. Maintain grass and ground cover in all unpaved areas	ongoing	April Moreno	
	2.			
Management of Runoff	1. Develop storm water monitoring program	4/1/09	Bruce Newton	
	2.			
Additional BMPs (Activity-specific and Site-specific)	1. Inspect and maintain deicing runoff controls per Drainage Plan update	est. 10/09	Philip Farzanegan	Final schedule on completion of improvements
	2.			

EMPLOYEE TRAINING		Worksheet #9 Completed by: <u>Bethel Burson Turner</u> Title: <u>Airport Manager</u> Date: <u>3/23/2008</u>	
Directions:	Describe the employee training program for each facility or specific activity. At a minimum the program should, if topics apply, address good housekeeping, spill prevention and response, and material management practices. Provide a schedule for the training program and the roster ID number that lists the employees who attended the training sessions. Attach additional sheets if necessary.		
Training Topics	Brief Description of Training Program and Materials (e.g., posters, newsletters, course, films)	Scheduled for Training (list dates)	Roster ID Number
Spill Prevention & Response	1. Fueling and pavement deicing operators - seminar, video	March & October	Fuel and deicing equipment operators
	2.		
	3.		
Good Housekeeping	1. Seminar on pollution prevention plan	April	All employees
	2.		
	3.		
Material Management Practices	1. Introduce hazardous material labels - workbook	March	Equipment operators
	2.		
	3.		
Other Topics	1. Storm water monitoring - workbook, video	April	Spill response team
	2.		
	3.		
	1.		
	2.		
	3.		

DEICING/ANTI-ICING RELEASES			Worksheet #10 Completed by: <u>Dee McCandless</u> Title: <u>Operations Coordinator</u> Date: <u>Dec 30, 2007</u>		
Directions:	Record the releases of pavement deicing/anti-icing chemicals as an aggregate of all deicing/anti-icing operations that occur during a 24 hour period. Attach additional sheets if necessary. (Information still needed for quantities used by airlines and other tenants).				
Date (Event Number#)	Location (rwy/twy/apron)	Type of Deicing/Anti-icing Product (by trade name)	Estimated Quantity (gallons)	Estimated Quantity (tons)	Comments
12/8/2007	1. All Aprons	potassium acetate	1,000		Total deicing operations for given date
	2. All taxiway	potassium acetate	3,150		
	3. Runway	potassium acetate	2,550		
12/9/2007	1. All Aprons	potassium acetate	1,200		
	2. All taxiway	potassium acetate	3,450		
	3. Runway	potassium acetate	2,750		
12/15/2007	1. All Aprons	potassium acetate	1,000		
	2. All taxiway	potassium acetate	3,100		
	3. Runway	potassium acetate	2,480		
12/28/2007	1. All Aprons	potassium acetate	1,100		
	2. All taxiway	potassium acetate	3,275		
	3. Runway	potassium acetate	2,650		
12/29/2007	1. All Aprons	potassium acetate	850		
	2. All taxiway	potassium acetate	2,300		
	3. Runway	potassium acetate	1,840		

APPENDIX E. SAMPLE OF AN EMERGENCY PLANNING & COMMUNITY RIGHT-TO-KNOW ACT (EPCRA) SECTION 313 AIRPORT TENANT FACILITY SWPPP

1. Attachment No. 2 addresses the SWPPP special requirements for an airport tenant subject to the reporting requirements under EPCRA Section 313. In this sample, Metalplate, Inc. (a fictitious corporation), the airport tenant in question, reports under this regulation. Accordingly, separate site assessment, plan design, evaluation, and implementation of BMPs are prepared to address the special requirements for the Metalplate site. Attachment 2 is a supplement to the airport's overall SWPPP because the airport and the tenant have a co-permittee agreement for the common drainage area that contributes storm water runoff to outfall #6.

ATTACHMENT NO. 2

SUPPLEMENT TO COUNTY AIRPORT

STORM WATER POLLUTION PREVENTION PLAN

METALPLATE, INC.

SPECIAL REQUIREMENTS FOR EPCRA

SECTION 313 REPORTING FACILITY

December 2008

Emergency Contact: Mr. Gene Menger P.E.

Title: Plant Manager

Phone: 904-426-8200

I. PLANNING AND ORGANIZATION

- A. **Member Roster.** See Airport SWPPP worksheet No. 1.
- B. **Consistency with Other Plans.** See Airport SWPPP.

II. SITE ASSESSMENT

- A. **Site Map.** See attached map in airport SWPPP and the accompanying checklist, airport SWPPP worksheet No. 2.
- B. **Material Inventory.**

All Metalplate Inc., significant materials that are exposed to precipitation are listed on worksheet No. 3, Attachment 2.
- C. **Past Spills and Leaks.** Not applicable.
- D. **Non-storm Water Discharge.** See Airport SWPPP worksheet No. 5.
- E. **Non-storm Water Discharge - Failure to Certify.** Not applicable.
- F. **Storm Water Data.** The general permit specifies that Metalplate, Inc., reporting under EPCRA Section 313, must perform semi-annual storm water monitoring for outfall no. 6. Two periods for monitoring are defined: (1) January - June, and (2) July - December. The results are due no later than the 28th of January, following the sampling year. The results of sampling periods must be presented on separate "Discharge Monitoring Report Forms" certified by a registered professional engineer, and submitted to:

Director of the NPDES Program
USEPA, Region VI, Water Management Division, (6W-EA)
Storm Water Staff
1445 Ross Avenue
Dallas, TX 75202

The storm water samples must be analyzed for: oil/grease, BOD₅, COD, TSS, TKN, total phosphorous, acute whole effluent toxicity, any Section 313 water priority chemicals for which the facility is subject to report under Section 313 of EPCRA. At a minimum, Metalplate, Inc., is subject to reporting for the following water priority chemicals:

- Trichlorethylene
- Hydrochloric Acid
- Phosphoric Acid
- Nitric Acid
- Chromic Acid

These chemicals must be analyzed in addition to the constituents listed above, for each storm water sample.

G. Risk Identification and Potential Pollutant Sources

1. **Pollutant Source Identification Summary, see worksheet No. 7, Attachment No. 2.**
2. **Site Assessment Report.**

The shop contains a vapor degreaser which utilizes trichlorethylene.

There is a concrete retaining wall around the storage tank area which provides secondary containment within the plating shop. The floor drains are connected to an acid neutralization system that provides pretreatment to wastewater. The treated waste is tested prior to discharge to the sanitary sewer system.

The plating shop has a covered loading dock for transfer of materials. The drains in the loading dock area are also connected to the above pretreatment system.

Most of the facility chemicals are stored outdoors under cover with fenced security. A three-foot (0.9M) concrete retaining wall provides secondary containment for the outdoor storage area. Drums of absorbent materials are kept in the storage area for spill control.

The nearest storm drain is located approximately 150 feet (45.7M) from the facility. The spill response team has a plug that may be installed in the drain pipe to prevent spills or leaks from entering the town's storm drain system.

All areas described above will be included in periodic and annual compliance inspections as required by the NPDES Storm Water Discharge Permit.

III. PLAN DESIGN - BASELINE BMP SELECTION NARRATIVE SUMMARY (SEE WORKSHEET 7A, ATTACHMENT 2)

A. **Good Housekeeping.** Chemical storage and handling areas are kept clean and free of obstacles. Drum storage is organized to allow free access during transfer of chemicals.

B. **Preventive Maintenance.** Chemical handling equipment, storage tanks, valves, pumps, and pipelines are routinely tested according to the manufacturer's recommendations. The floor drain system is inspected monthly for obstructions and leaks.

C. **Visual Inspections.** Gene Menger, plant manager, is responsible for maintaining a qualified inspection and maintenance staff. He receives all inspection reports and keeps a log of inspection follow-up activities. Inspection records of storm water control facilities are filed in Section V.B of the airport SWPPP. Inventory of chemicals is taken monthly.

D. **Spill Prevention and Response.** Spills that may impact storm water quality would occur at either the loading docks or outdoor chemical storage areas. The airport SWPPP site map building reference shows the locations of these activities. A spill response team is ready to respond to leaks and spills. Drums of absorbent materials are kept in the chemical transfer areas.

E. **Sediment and Erosion Control.** All unpaved areas are planted with grasses and ground cover to limit erosion. Silt fencing is used during minor site work and pavement repairs.

F. **Management of Runoff.** On site runoff is controlled by means of grading and diversion around the chemical storage and handling areas. Storm water runoff is directed to outfall no. 6 or the local POTW. The receiving waters for these outfalls are New Castle Creek. Storm water monitoring will be performed at sampling location No. 6, downstream of outfall No. 4.

IV. IMPLEMENTATION SCHEDULE

A. **BMP Schedule Summary.** See worksheet No. 8, Attachment No. 2.

B. **Employee Training Schedule.** See worksheet No. 9, Attachment No. 2.

END

**Attachment No. 2
MATERIAL INVENTORY
Metalplate, Inc.**

Worksheet #3
Completed by: Gene Menger, P.E.
Title: Manager
Date: December 15, 2008

Directions: List all materials used, stored, or produced on site. Assess and evaluate these materials for their potential to contribute pollutants to storm water runoff. Also complete Worksheet 3A if the material has been exposed during the last 3 years.

Material	Location	Quantity (units)			Quantity Exposed in Last 3 Years	Likelihood of contact with storm water. If yes, describe reason.	Past Significant Spill or Leak	
		Used	Produced	Stored			Yes	No
Isopropyl alcohol (liquid)	45S		275			Drums stored under cover inside 3-foot (0.9M) concrete retaining wall		x
Trichloroethylene (liquid)	45S		110			Storm water contact unlikely		x
Paint stripper	45S		300					x
Soap (liquid)	45S		550					x
Lubricant	45S		55					x
Solvent	45S		55					x
Hydrochloric acid (liquid)	45S		500					x
Phosphoric acid (liquid)	45S		100					x
Chromic acid	45S		1000 lb					x
Plating chemicals (liquid)	45S		220					x
Nitric acid (liquid)	45S		300					x
Chrome stripper (dry)	45S		500 lb					x

**Attachment No. 2
 POLLUTANT SOURCE IDENTIFICATION
 Metalplate, Inc.**

Worksheet #7
Completed by: Gene Menger, P.E.
Title: Manager
Date: December 15, 2008

Directions: List all identified storm water pollutant sources and describe existing management practices that address those sources. In the third column, list BMP options that can be incorporated into the plan to address remaining sources of pollutants.

Storm Water Pollutant Sources	Existing Management Practices	Description of New BMP Options
1. Covered, outdoor, fenced storage area	Drums are stored inside concrete retaining wall	None required
2.	Absorbent materials are stored with other chemicals	
3.		
4.		
5.		
6.		
7.		
8.		
9.		
10.		
11.		

**Attachment No. 2
BMP IDENTIFICATION
Metalplate, Inc.**

Worksheet #7A
Completed by: Gene Menger, P.E.
Title: Manager
Date: December 15, 2008

Directions: Describe the Best Management Practices (BMPs) that you have selected to include in your plan. For each of the baseline BMPs, describe actions that will be incorporated into the airport or facility operations. Also describe any additional BMPs that you have selected. Attach additional sheets if necessary.

BMPs	Brief Description of Activities
Good Housekeeping	Chemical storage and handling areas are kept clean and free of obstacles. Drums are stored in a manner that minimizes the potential for damage and spills.
Preventative Maintenance	Chemical handling equipment is routinely inspected. Facility piping, pumps, and chemical storage tanks are routinely inspected for failure conditions. The chemical drains and acid neutralization system are checked for obstructions and leaks.
Inspections	Visual inspections of chemical handling facilities are performed daily. Monthly inspections include material inventory.
Spill Prevention & Response	Loading and unloading of plating chemicals is performed inside concrete retaining wall (outdoors) and behind curbed area inside covered loading dock. Absorbent materials are readily available to contain spills.
Sediment and Erosion Control	Unpaved areas are grassed or planted with ground cover.
Management of Runoff	Storm water is directed away from chemical storage and handling areas.
Additional BMPs (Activity-specific and Site-specific)	No additional BMPs are planned.

**Attachment No. 2
IMPLEMENTATION
Metalplate, Inc.**

Worksheet #8
Completed by: Gene Menger, P.E.
Title: Manager
Date: December 15, 2008

Directions: Develop a schedule for implementing each BMP. Provide a brief description of each BMP, the steps necessary to implement the BMP (i.e., any design or construction), the schedule for completing those steps (list dates) and the person(s) responsible for implementation. Attach additional sheets if necessary.

BMPs	Description of Action(s) Required for Implementation	Scheduled Completion Date(s) for Actions	Person Responsible for Action(s)	Notes
Good Housekeeping	1.			
	2.			
	3.			
Preventative Maintenance	1.			
	2.			
	3.			
Inspections	1.			
	2.			
	3.			
Spill Prevention & Response	1. Employee training	March & Oct	Menger	
	2. Inspect spill response equipment	Weekly	Menger	
	3. Inspect chemical handling equipment	each shift	Menger	
Sediment and Erosion Control	1.			
	2.			
	3.			
Management of Runoff	1. Storm water monitoring	Jan – June	Menger	Outfall #6
	2. (semi-annual)	July – Dec	Menger	Outfall #6
	3.			
Additional BMPs (Activity-specific and Site-specific)	1.			
	2.			
	3.			

Attachment No. 2 EMPLOYEE TRAINING Metalplate, Inc.		Worksheet #9 Completed by: <u>Gene Menger, P.E.</u> Title: <u>Manager</u> Date: <u>12/15/2008</u>	
Directions:	Describe the employee training program for each facility or specific activity. At a minimum the program should, if topics apply, address good housekeeping, spill prevention and response, and material management practices. Provide a schedule for the training program and the roster ID number that lists the employees who attended the training sessions. Attach additional sheets if necessary.		
Training Topics	Brief Description of Training Program and Materials (e.g., posters, newsletters, course, films)	Scheduled for Training (list dates)	Roster ID Number
Good Housekeeping	1. Seminar on pollution prevention plan (PPP).	April (annual)	All employees
	2. Review plan requirements	April (annual)	All employees
	3.		
Spill Prevention & Response	1. 3 day emergency response training.	March & October	Spill response team
	2. 1 day annual refresher/workbook, videos.	March & October	Spill response team
	3.		
Material Management Practices	1. 1 day hazardous waste management/workbook, videos	March (annual)	All employees
	2.		
	3.		
Other Topics	1. Storm water monitoring/ workbook, video	February (annual)	Spill response team
	2.		
	3.		
Pollution Control Laws and Regulations	1. Seminar/workbook	January (annual)	PPP team
	2.		
	3.		

Intentionally left blank.